

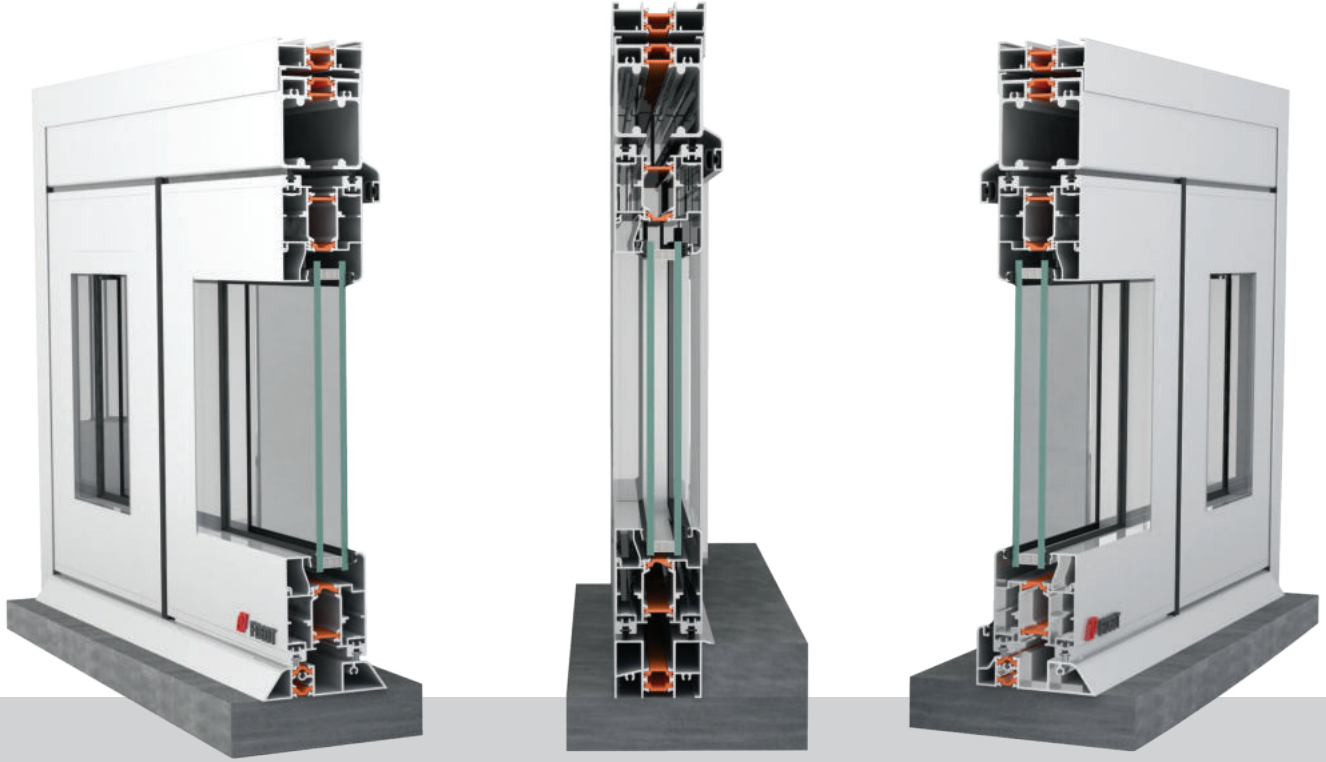

Kapı - Pencere Sistem  
Door - Window System

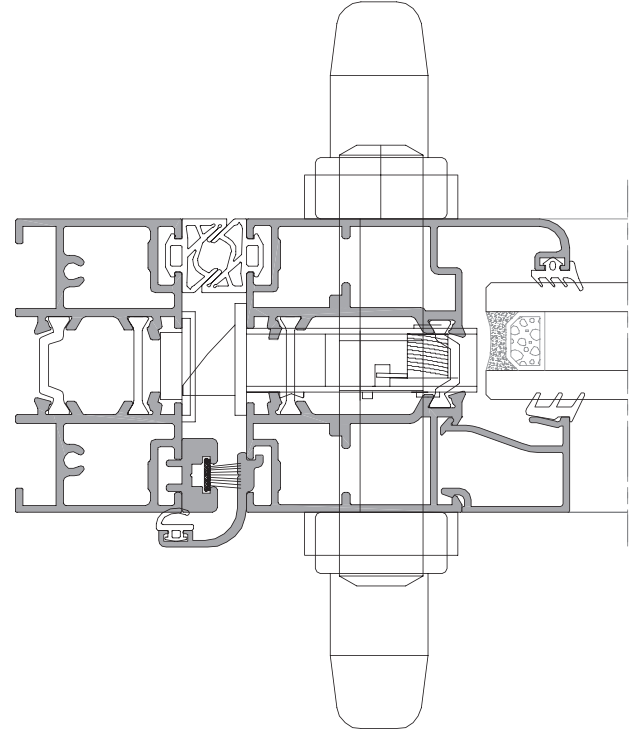

# FD60T



### TEKNİK ÖZELLİKLER / TECHNICAL PROPERTIES

<b>KASA DERİNLİĞİ / FRAME DEPTH</b>	<b>60 mm</b>
<b>KANAT DERİNLİĞİ / SASH DEPTH</b>	<b>60 mm</b>
<b>ET KALINLIĞI / WALL THICKNESS</b>	<b>1.3 mm - 2 mm</b>
<b>MİN/MAX CAM KALINLIĞI / MIN/MAX GLASS THICKNESS</b>	<b>4 mm - 36 mm</b>
<b>ISI BARIYER / THERMAL BREAK</b>	<b>20 mm</b>
<b>ISI YALITIM DEĞERİ / THERMAL INSULATION VALUE (UF)</b>	<b>2.35 - 3.27 W / ( m<sup>2</sup> . K )</b>
<b>MAKS. KANAT AĞIRLIĞI / MAX. SASH WEIGH</b>	<b>80 kg</b>

### UYGULAMA SEÇENEKLERİ / APPLICATION OPTIONS

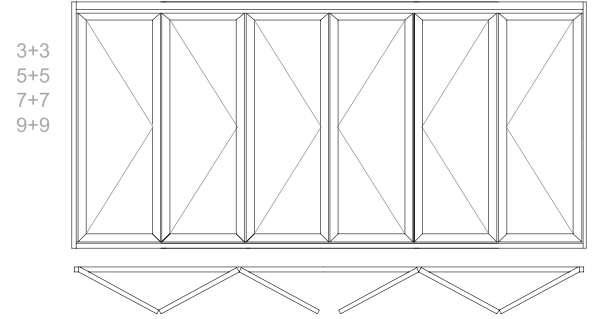
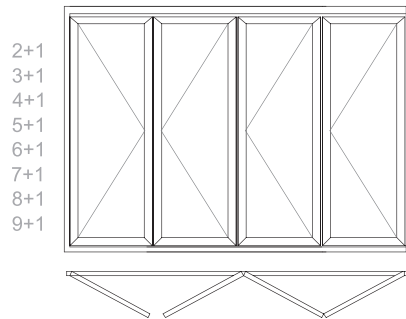
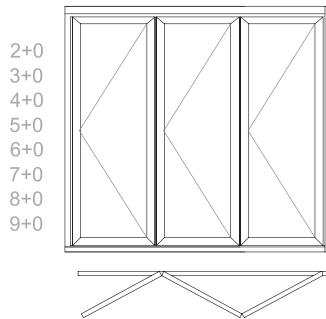

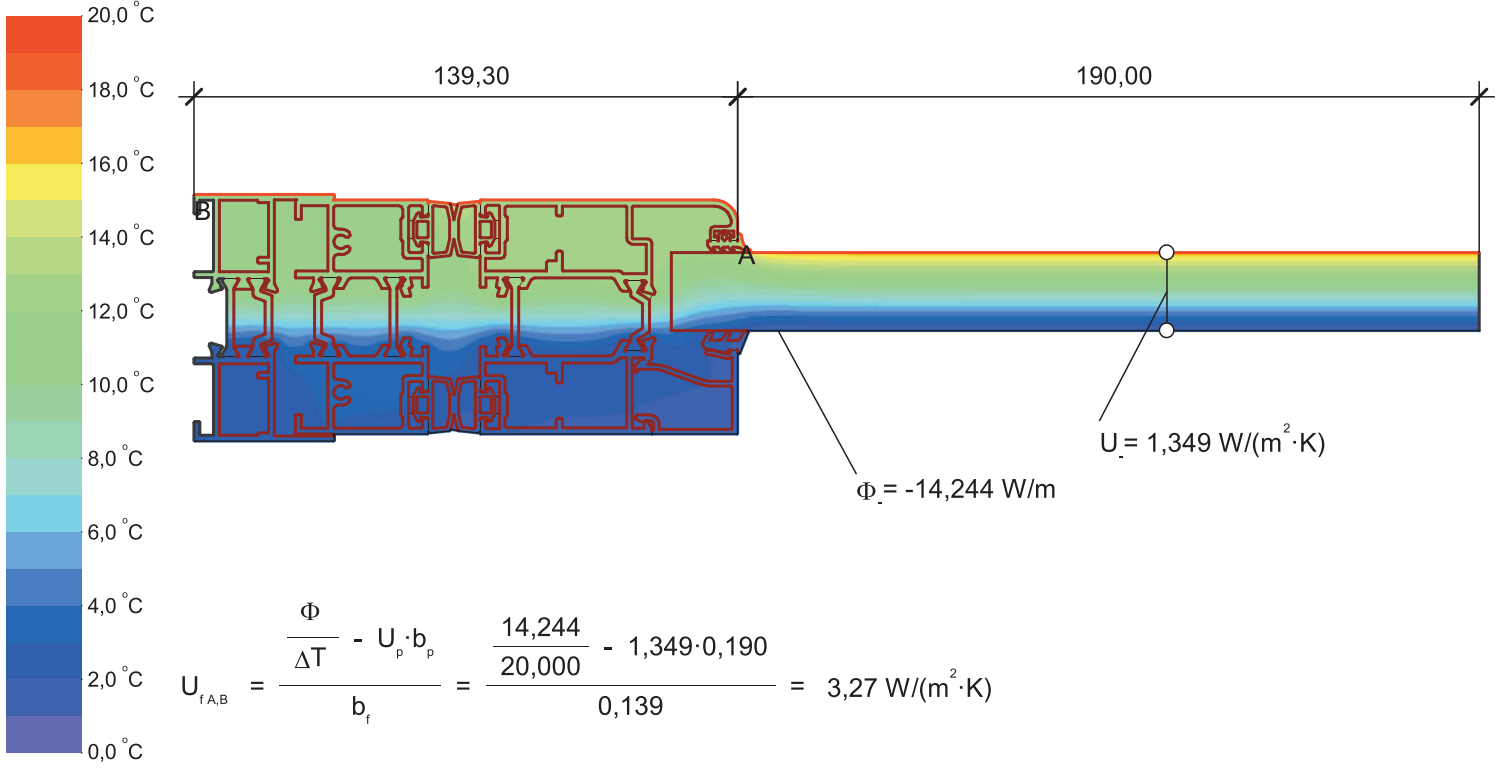

$$U_{f,A,B} = \frac{\frac{\Phi}{\Delta T} - U_p \cdot b_p}{b_f} = \frac{\frac{14,244}{20,000} - 1,349 \cdot 0,190}{0,139} = 3,27 \text{ W/(m}^2 \cdot \text{K)}$$



Material	$\lambda$ [W/(m·K)]	$\epsilon$	Boundary Condition	$q$ [W/m <sup>2</sup> ]	$\theta$ [°C]	$R$ [(m <sup>2</sup> ·K)/W]	$\epsilon$
Aluminium (Si Alloys)	160,000	0,900	Epsilon 0.9				0,900
EPDM (ethylene propylene diene monomer)	0,250	0,900	Exterior, frame	0,000		0,040	
Panel	0,035	0,900	Interior, normal, horizontal	20,000		0,130	
Polyamid 6.6 with 25% glass fibre	0,300	0,900	Symmetry/Model section	0,000			
Unventilated air cavity	anisotropic						

PROFİL KESİTİ PROFILE SECTION	PROFİL KODU PROFILE CODE	PROFİL ADI PROFILE NAME	Jx cm <sup>4</sup>	Jy cm <sup>4</sup>	AĞIRLIK (kg/m) WEIGHT
	3663-3664	ÜST KASA PROFİLİ TOP FRAME PROFILE	57,47 cm <sup>4</sup>	54,20 cm <sup>4</sup>	2,664 kg/m
	3662-3662	ALT KASA PROFİLİ BOTTOM FRAME PROFILE	5,03 cm <sup>4</sup>	18,28 cm <sup>4</sup>	1,402 kg/m
	3660-3661	KANAT PROFİLİ (OVAL) SASH PROFILE (OVAL)	19,72 cm <sup>4</sup>	25,63 cm <sup>4</sup>	1,764 kg/m
	13006-13007	KANAT PROFİLİ (DÜZ) SASH PROFILE (STRAIGHT)	23,33 cm <sup>4</sup>	19,52 cm <sup>4</sup>	1,615 kg/m
	3665-3665	YAN BAZA PROFİLİ SIDE BASE PROFILE	2,47 cm <sup>4</sup>	17,47 cm <sup>4</sup>	1,108 kg/m
	11830-11831	ORTA KAYIT PROFİLİ MULLION PROFILE	15,69 cm <sup>4</sup>	7,77 cm <sup>4</sup>	1,228 kg/m
	3666-3667	ALT EŞİK PROFİLİ BOTTOM THRESHOLD PROFILE	6,25 cm <sup>4</sup>	19,63 cm <sup>4</sup>	1,357 kg/m
	3666-3666	ALT EŞİK PROFİLİ BOTTOM THRESHOLD PROFILE	5,69 cm <sup>4</sup>	17,73 cm <sup>4</sup>	1,306 kg/m
	3667-3667	ALT EŞİK PROFİLİ BOTTOM THRESHOLD PROFILE	6,81 cm <sup>4</sup>	20,63 cm <sup>4</sup>	1,364 kg/m
	11834-11833	BİNİLİ ALT EŞİK PROFİLİ OVERLAPPING BOTTOM THRESHOLD PROFILE	6,39 cm <sup>4</sup>	37,19 cm <sup>4</sup>	1,433 kg/m
	11832-11833	ALT EŞİK PROFİLİ BOTTOM THRESHOLD PROFILE	3,03 cm <sup>4</sup>	31,64 cm <sup>4</sup>	1,315 kg/m
	11835-11836	KÖŞE DÖNÜŞ PROFİLİ CORNER PROFILE	30,61 cm <sup>4</sup>	30,03 cm <sup>4</sup>	2,029 kg/m
	7241	KAPAK PROFİLİ COVER PROFILE	31,20 cm <sup>4</sup>	17,29 cm <sup>4</sup>	0,084 kg/m
	3668	FIRÇA ADAPTÖR PROFİLİ BRUSH ADAPTER PROFILE	-	-	0,237 kg/m
	13008	ADAPTÖR PROFİLİ (DÜZ) ADAPTER PROFILE (STRAIGHT)	-	-	0,205 kg/m
	3669	ADAPTÖR PROFİLİ (OVAL) ADAPTER PROFILE (OVAL)	-	-	0,199 kg/m
	8241	FIRÇA ADAPTÖR PROFİLİ BRUSH ADAPTER PROFILE	-	-	0,099 kg/m
	3537	CAM ÇİTASI (41,5 mm) GLAZING BEAD (41,5 mm)	-	-	0,367 kg/m
	1749	CAM ÇİTASI (38,5 mm) GLAZING BEAD (38,5 mm)	-	-	0,356 kg/m
	1747	CAM ÇİTASI (34,5 mm) GLAZING BEAD (34,5 mm)	-	-	0,340 kg/m
	3536	CAM ÇİTASI (31,5 mm) GLAZING BEAD (31,5 mm)	-	-	0,329 kg/m
	3636	CAM ÇİTASI (29,5 mm) GLAZING BEAD (29,5 mm)	-	-	0,321 kg/m

\*\* Her profil için minimum sipariş 300 kg'dır.  
\*\* Minimum order quantity is 300 kg per profile.

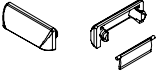
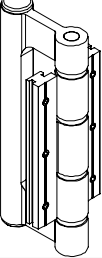
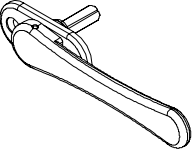

AKSESUAR ACCESSORY	STOK KODU REFERENCE CODE	AKSESUAR ADI DESCRIPTION	AKSESUAR KODU PRODUCT CODE	PAKET PACK
	03 010437	BİNİ FİTİLİ OVERLAP GASKET	FD60T-BF.15	104 mt / paket 10 kg
	03 010442	BİNİ FİTİLİ OVERLAP GASKET	FD60T-KBF.60	110 mt / paket 10 kg
	03 010106	DIŞ CAM FİTİLİ OUTER GLAZING GASKET	FD60T-DCF.25	240 mt / paket 10 kg
	03 010446	KASA FİTİLİ FRAME GASKET	FD60T-KBF.46	275 mt / paket 10 kg
	03 010438	KASA KANAT FİTİLİ FRAME GASKET	FD60T-KBF.70	303 mt / paket 10 kg
	03 011230	İÇ CAM FİTİLİ INNER GLAZING GASKET	FD60T-İCF.30	330 mt / paket 10 kg
	03 011231	İÇ CAM FİTİLİ INNER GLAZING GASKET	FD60T-İCF.40	205 mt / paket 10 kg
	03 010732	İÇ CAM FİTİLİ INNER GLAZING GASKET	FD60T-İCF.50	175 mt / paket 10 kg
	03 010447	ÜST RAY BİNİ FİTİLİ TOP RAIL GASKET	FD60T-KBF.65	25 mt / paket 10 kg
	03 050712	FİRÇA FİTİLİ (6.8 - 10 mm) WEATHER STRIP (6.8 - 10 mm)	FD60T-FÇ.712	200 mt / 1 pk
	01 200110	ALYAN KÖŞE BAĞLANTI ALLEN CORNER JOINT	FD60T-MC.110	250 ad / 1 pk
	01 200320	RULMANLI KATLANIR KAPI MENTEŞE ÜST (SİYAH) FOLDING DOOR HINGE (BLACK)	FD60T-RMS.320	1 ad / 1 pk
	01 200321	RULMANLI KATLANIR KAPI MENTEŞE ÜST (BEYAZ) FOLDING DOOR HINGE (WHITE)	FD60T-RMS.321	1 ad / 1 pk
	01 200323	RULMANLI KATLANIR KAPI MENTEŞE ÜST (NATURAL) FOLDING DOOR HINGE (NATURAL)	FD60T-RMS.323	1 ad / 1 pk
	01 200324	RULMANLI KATLANIR KAPI MENTEŞE ALT (BEYAZ) FOLDING DOOR HINGE (WHITE)	FD60T-RML.324	1 ad / 1 pk
	01 200326	RULMANLI KATLANIR KAPI MENTEŞE ALT (NATURAL) FOLDING DOOR HINGE (NATURAL)	FD60T-RML.326	1 ad / 1 pk
	01 200327	RULMANLI KATLANIR KAPI MENTEŞE ALT (SİYAH) FOLDING DOOR HINGE (BLACK)	FD60T-RML.327	1 ad / 1 pk
	01 200286	KATLANIR KAPI MENTEŞESİ (SİYAH) FOLDING DOOR HINGE (BLACK)	FD60T-KM.286	100 ad / 1 pk
	01 200287	KATLANIR KAPI MENTEŞESİ (NATURAL) FOLDING DOOR HINGE (NATURAL)	FD60T-KM.287	100 ad / 1 pk
	01 200288	KATLANIR KAPI MENTEŞESİ (BEYAZ) FOLDING DOOR HINGE (WHITE)	FD60T-KM.288	100 ad / 1 pk

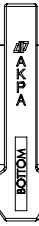
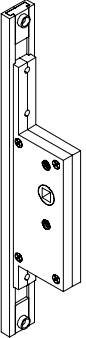
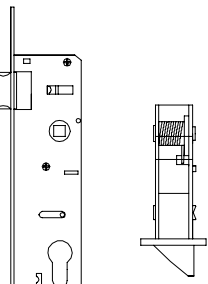
AKSESUAR ACCESSORY	STOK KODU REFERENCE CODE	AKSESUAR ADI DESCRIPTION	AKSESUAR KODU PRODUCT CODE	PAKET PACK
	04 010112	HAREKETLİ PERDELİ YAĞMUR TAHLİYE KAPAK WATER DRAIN COVER (MOVEABLE)	FD60T-TK.112	1000 ad / 1 pk
	01 200305	ÇEKME KOL (SİYAH) PULL HANDLE (BLACK)	FD60T-ÇK.305	100 ad / 1 pk
	01 200306	ÇEKME KOL (NATURAL) PULL HANDLE (NATURAL)	FD60T-ÇK.306	100 ad / 1 pk
	01 200307	ÇEKME KOL (BEYAZ) PULL HANDLE (WHITE)	FD60T-ÇK.307	100 ad / 1 pk
	01 200310	ÇİFT YÖNLÜ KİLİTLEME KOL (SİYAH) GEARBOX HANDLE (BLACK)	FD60T-KST.310	100 ad / 1 pk
	01 200311	ÇİFT YÖNLÜ KİLİTLEME KOL (NATURAL) GEARBOX HANDLE (NATURAL)	FD60T-KST.311	100 ad / 1 pk
	01 200312	ÇİFT YÖNLÜ KİLİTLEME KOL (BEYAZ) GEARBOX HANDLE (WHITE)	FD60T-KST.312	100 ad / 1 pk
	01 200331	TERMİNAL SÜRGÜ ÜST TERMINAL LATCH TOP	FD60T-TSÜ.331	100 ad / 1 pk
	01 200332	TERMİNAL SÜRGÜ ALT TERMINAL LATCH BOTTOM	FD60T-TSA.332	100 ad / 1 pk
	01 200330	ÇİFT YÖNLÜ İSPANYOLET GÖVDESİ GEARBOX ESPAGNOLETTE BODY	FD60T-İG.330	50 ad / 1 pk
	05 010401	153/35 DİLLİ KİLİT 153/35 BOLT LOCK	FD60T-DK.401	30 ad / 1 pk





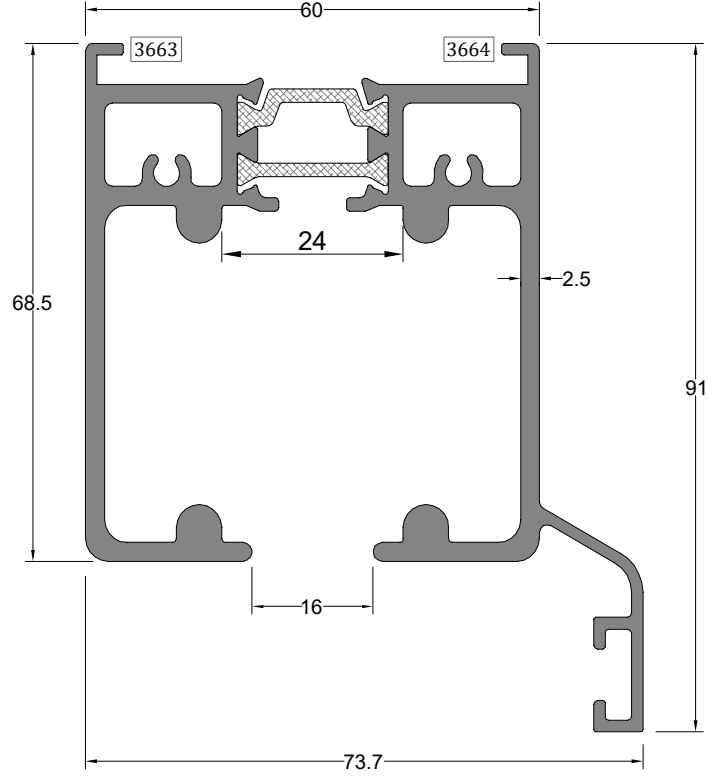

Üst Kasa Profili TOP FRAME PROFILE	Profil Kodu Profile Code	(kg/mt) weight	Jx cm <sup>4</sup>	Jy cm <sup>4</sup>
	3663-3664	2,664	57,47	54,20

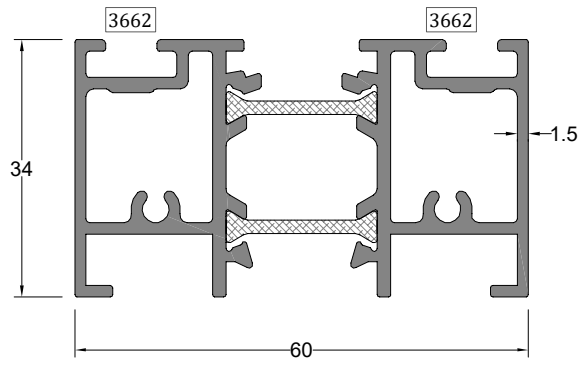

Alt Kasa Profili BOTTOM FRAME PROFILE	Profil Kodu Profile Code	(kg/mt) weight	Jx cm <sup>4</sup>	Jy cm <sup>4</sup>
	3662-3662	1,402	5,03	18,28

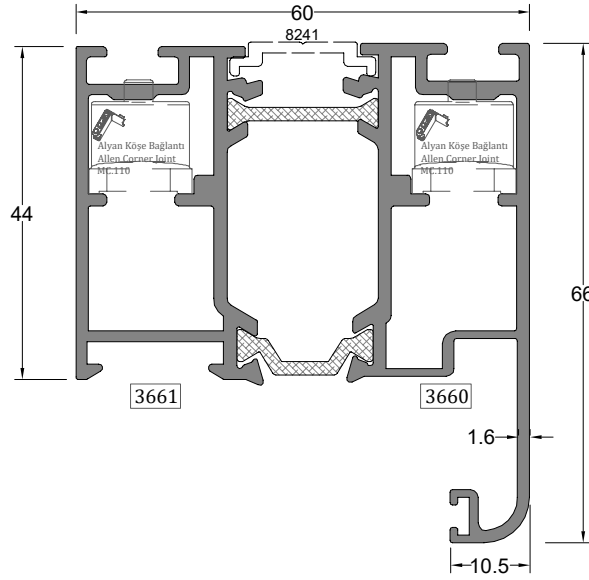

Kanat Profili (Oval)	Profil Kodu Profile Code	(kg/mt) weight	Jx cm <sup>4</sup>	Jy cm <sup>4</sup>
SASH PROFILE (OVAL)	3660-3661	1,764	19,72	25,63

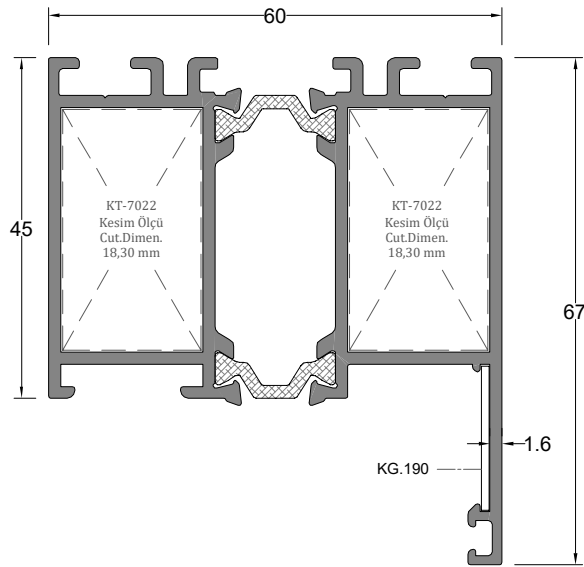

Kanat Profili (Düz)	Profil Kodu Profile Code	(kg/mt) weight	Jx cm <sup>4</sup>	Jy cm <sup>4</sup>
SASH PROFILE (STRAIGHT)	13006-13007	1,615	23,33	19,52

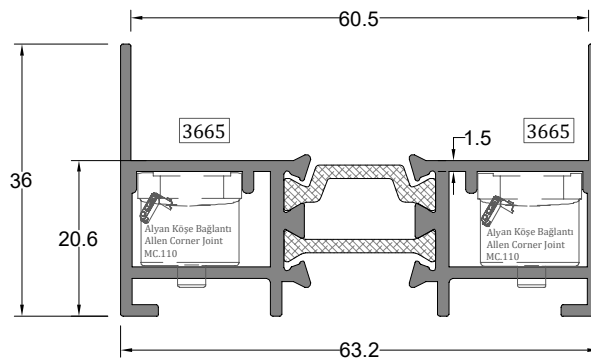

Yan Baza Profili	Profil Kodu Profile Code	(kg/mt) weight	Jx cm <sup>4</sup>	Jy cm <sup>4</sup>
SIDE BASE PROFILE	3665-3665	1,108	2,47	17,47

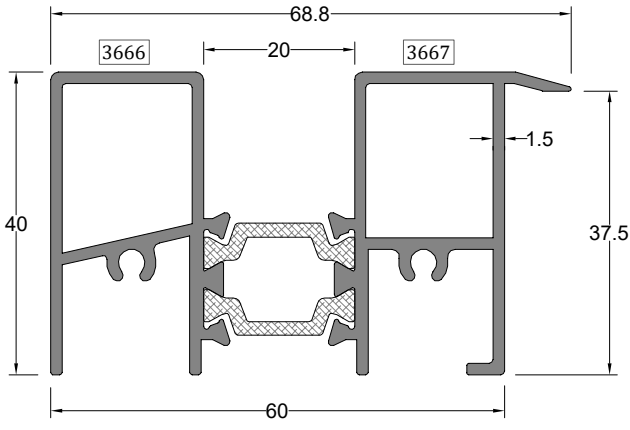

Alt Eşik Profili	Profil Kodu	(kg/mt)	Jx cm <sup>4</sup>	Jy cm <sup>4</sup>
BOTTOM THRESHOLD PROFILE	Profile Code	weight		
	3666-3667	1,357	6,25	19,63

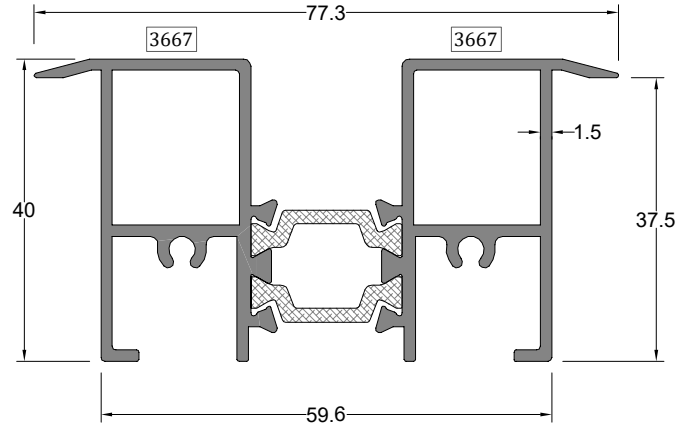

Alt Eşik Profili	Profil Kodu	(kg/mt)	Jx cm <sup>4</sup>	Jy cm <sup>4</sup>
BOTTOM THRESHOLD PROFILE	Profile Code	weight		
	3667-3667	1,364	6,81	20,63

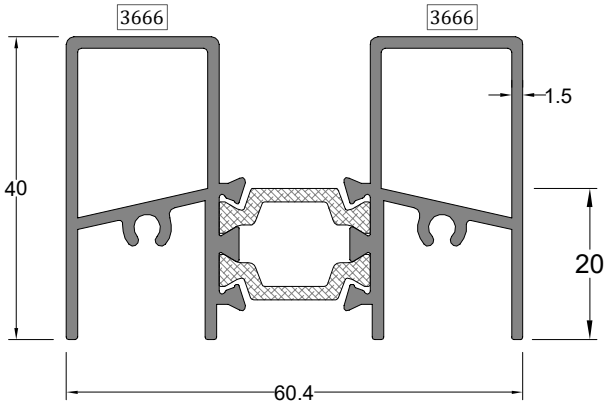

Alt Eşik Profili	Profil Kodu	(kg/mt)	Jx cm <sup>4</sup>	Jy cm <sup>4</sup>
BOTTOM THRESHOLD PROFILE	Profile Code	weight		
	3666-3666	1,306	5,69	17,73

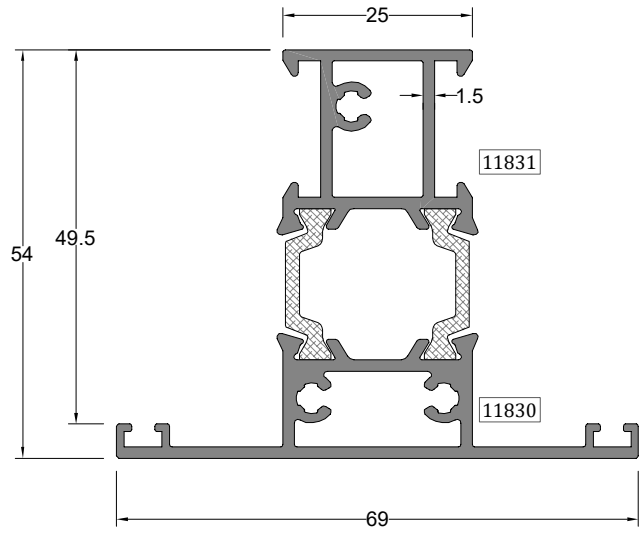

Orta Kayıt Profili	Profil Kodu	(kg/mt)	Jx cm <sup>4</sup>	Jy cm <sup>4</sup>
MULLION PROFILE	Profile Code	weight		
	11830-11831	1,288	15,69	7,77

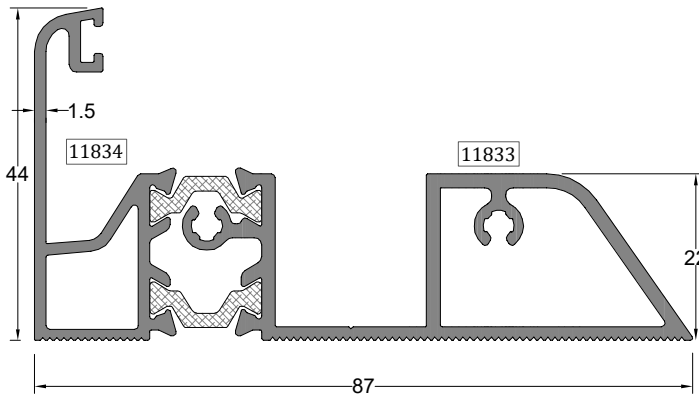

Binili Alt Eşik Profili	Profil Kodu	(kg/mt)	Jx cm <sup>4</sup>	Jy cm <sup>4</sup>
OVERLAPPING BOTTOM THRESHOLD PROFILE	Profile Code	weight		
	11834-11833	1,433	6,39	37,19

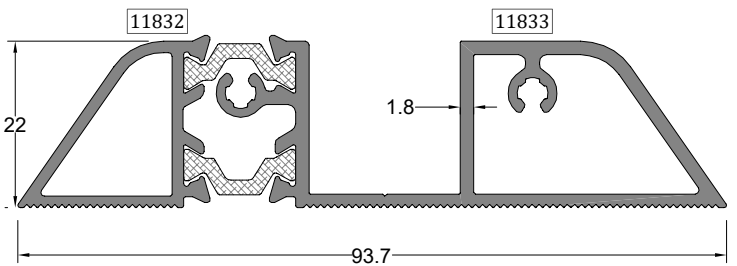

Alt Eşik Profili	Profil Kodu	(kg/mt)	Jx cm <sup>4</sup>	Jy cm <sup>4</sup>
BOTTOM THRESHOLD PROFILE	Profile Code	weight		
	11832-11833	1,315	3,03	31,64

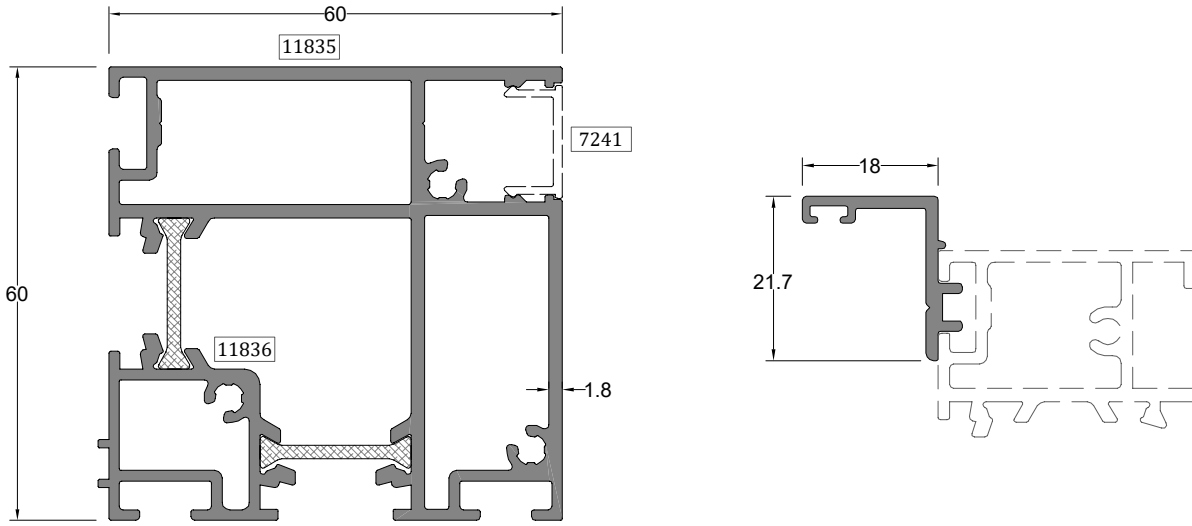

90° Köşe Dönüş Profili	Profil Kodu	(kg/mt)	Jx cm <sup>4</sup>	Jy cm <sup>4</sup>
90° CORNER PROFILE	Profile Code	weight		
	11835-11836	2,029	30,61	30,03

Adaptör Profili (Düz)	Profil Kodu	(kg/mt)
ADAPTER PROFILE (STRAIGHT)	Profile Code	Weight
	13008	0,205

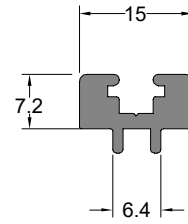
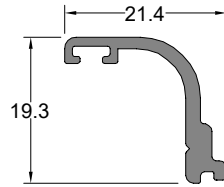
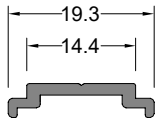

Tij Profili	Profil Kodu	(kg/mt)
STEM BAR PROFILE	Profile Code	Weight
	8241	0,099

Adaptör Profili (Oval)	Profil Kodu	(kg/mt)
ADAPTER PROFILE (OVAL)	Profile Code	Weight
	3669	0,199

Fırça Adaptörü	Profil Kodu	(kg/mt)
BRUSH ADAPTER	Profile Code	Weight
	3668	0,237

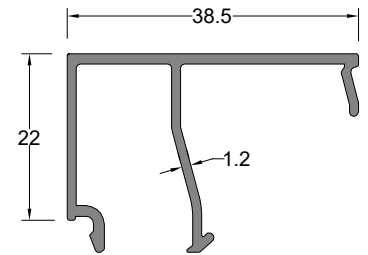
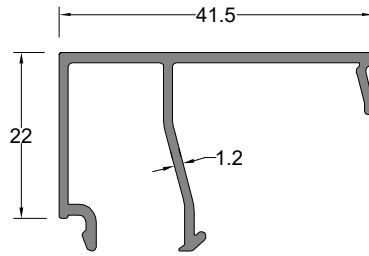
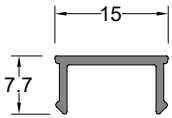

Kapak Profili	Profil Kodu	(kg/mt)
COVER PROFILE	Profile Code	Weight
	7241	0,084

Cam Çıtası	Profil Kodu	(kg/mt)
GLAZING BEAD	Profile Code	Weight
	3537	0,367

Cam Çıtası	Profil Kodu	(kg/mt)
GLAZING BEAD	Profile Code	Weight
	1749	0,356

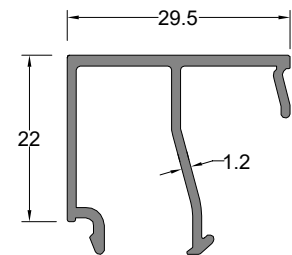
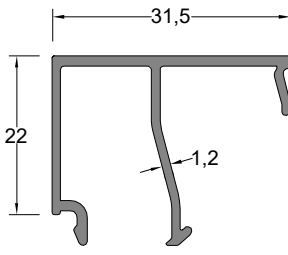
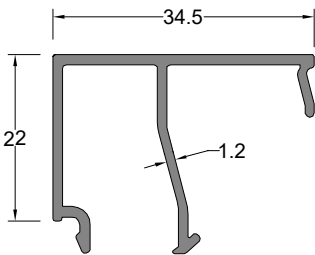

Cam Çıtası	Profil Kodu	(kg/mt)
GLAZING BEAD	Profile Code	Weight
	1747	0,340

Cam Çıtası	Profil Kodu	(kg/mt)
GLAZING BEAD	Profile Code	Weight
	3536	0,329

Cam Çıtası	Profil Kodu	(kg/mt)
GLAZING BEAD	Profile Code	Weight
	3636	0,321

\*\* Her profil için minimum sipariş 300 kg'dır.  
\*\* Minimum order quantity is 300 kg per profile.

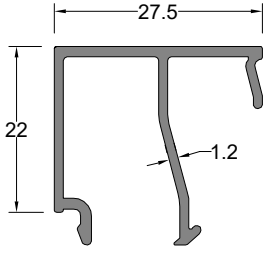

Cam Çıtası GLAZING BEAD	Profil Kodu Profile Code	(kg/mt) Weight
	1966	0,314

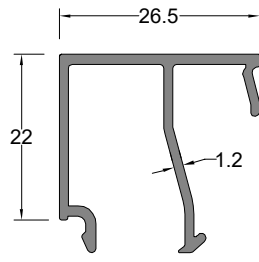

Cam Çıtası GLAZING BEAD	Profil Kodu Profile Code	(kg/mt) Weight
	2236	0,310

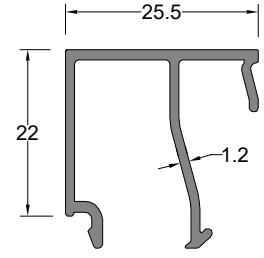

Cam Çıtası GLAZING BEAD	Profil Kodu Profile Code	(kg/mt) Weight
	1949	0,306

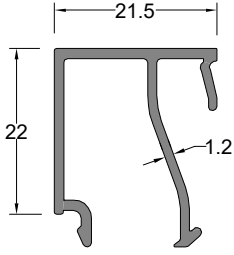

Cam Çıtası GLAZING BEAD	Profil Kodu Profile Code	(kg/mt) Weight
	1745	0,292

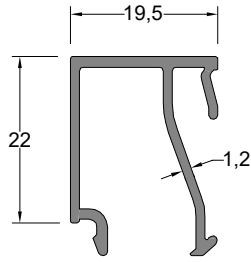

Cam Çıtası GLAZING BEAD	Profil Kodu Profile Code	(kg/mt) Weight
	1699	0,285

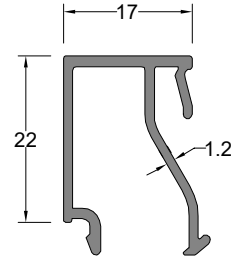

Cam Çıtası GLAZING BEAD	Profil Kodu Profile Code	(kg/mt) Weight
	3539	0,277

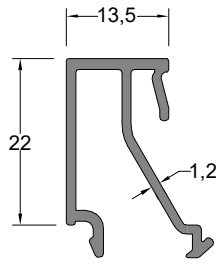

Cam Çıtası GLAZING BEAD	Profil Kodu Profile Code	(kg/mt) Weight
	1698	0,253

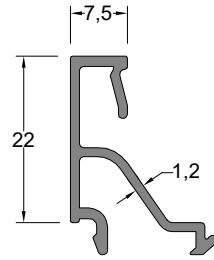

Cam Çıtası GLAZING BEAD	Profil Kodu Profile Code	(kg/mt) Weight
	1948	0,225

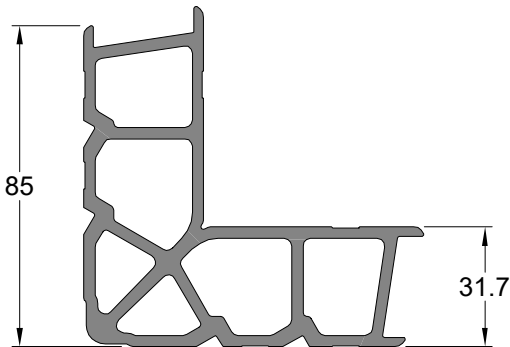

Köşe Takoz Profili CORNER WEDGE PROFILE	Profil Kodu Profile Code	(kg/mt) Weight
	7022	3,952

Köşe Takozu Profil Kodu Corner Wedge Profile Code	Kullanıldığı Profil Compatible Profile	Kesim Boyu (mm) Cutting Length (mm)
7022	13006	18,30 mm
	13007	18,30 mm

CAM ÇİTASI GLAZING BEAD	CAM ÇİTASI UZUNLUĞU GLAZING BEAD LENGTH	İÇ CAM FİTİLİ GLAZING GASKET(inside)	CAM KALINLIĞI GLASS THICKNESS	DIŞ CAM FİTİLİ GLAZING GASKET(outside)
(G)	(L)	(I)	(T)	(O)
1749	41,5 mm	İCF.50	4 mm	DCF.25
1750	38,5 mm	İCF.40	5 mm	DCF.25
1749	38,5 mm	İCF.30	6 mm	DCF.25
1747	34,5 mm	İCF.50	8 mm	DCF.25
1748	34,5 mm	İCF.40	9 mm	DCF.25
1747	34,5 mm	İCF.30	10 mm	DCF.25
3536	31,5 mm	İCF.50	11 mm	DCF.25
3536	31,5 mm	İCF.40	12 mm	DCF.25
3536	31,5 mm	İCF.30	13 mm	DCF.25
3636	29,5 mm	İCF.40	14 mm	DCF.25
3636	29,5 mm	İCF.30	15 mm	DCF.25
1966	27,5 mm	İCF.40	16 mm	DCF.25
2236	26,5 mm	İCF.40	17 mm	DCF.25
1949	25,5 mm	İCF.40	18 mm	DCF.25
5527	25,5 mm	İCF.30	19 mm	DCF.25
1745	21,5 mm	İCF.50	20 mm	DCF.25
1745	21,5 mm	İCF.50	21 mm	DCF.25
1745	21,5 mm	İCF.40	22 mm	DCF.25
1746	21,5 mm	İCF.30	23 mm	DCF.25
5546	19,5 mm	İCF.40	24 mm	DCF.25
1699	19,5 mm	İCF.30	25 mm	DCF.25

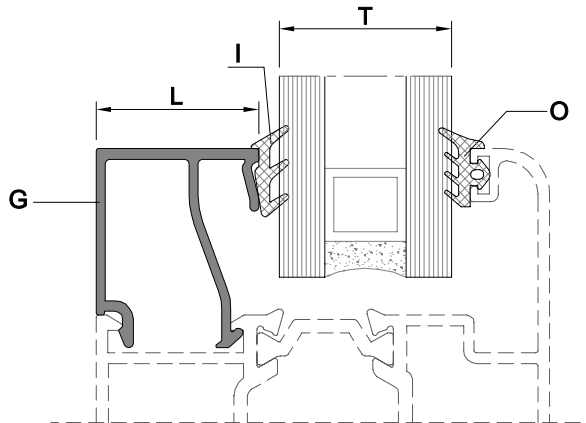



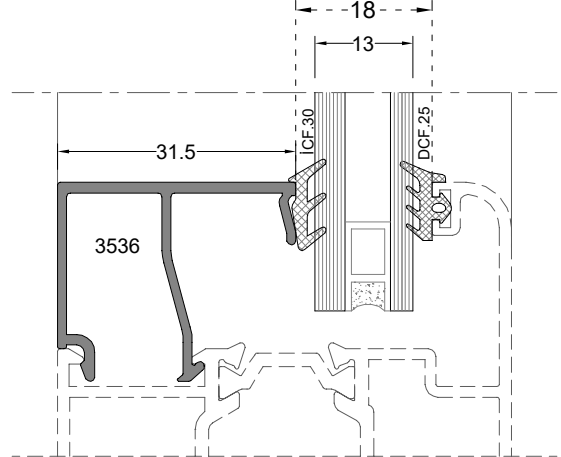
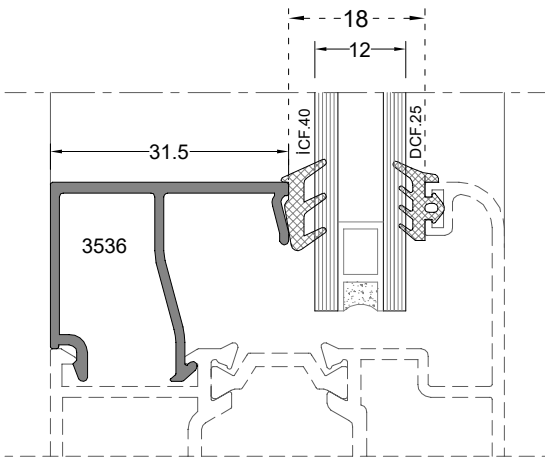
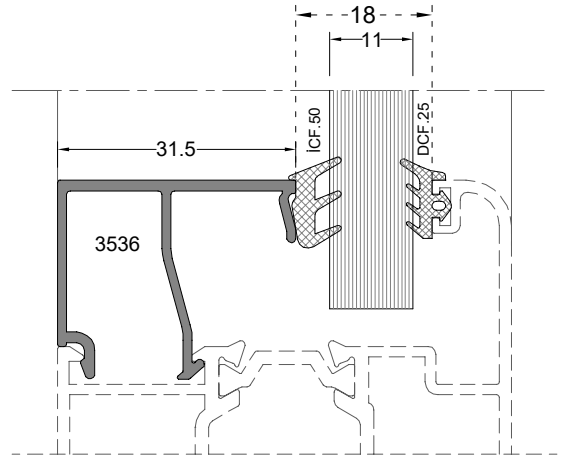
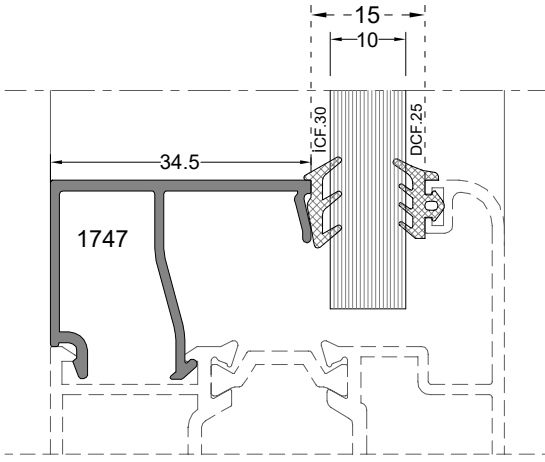
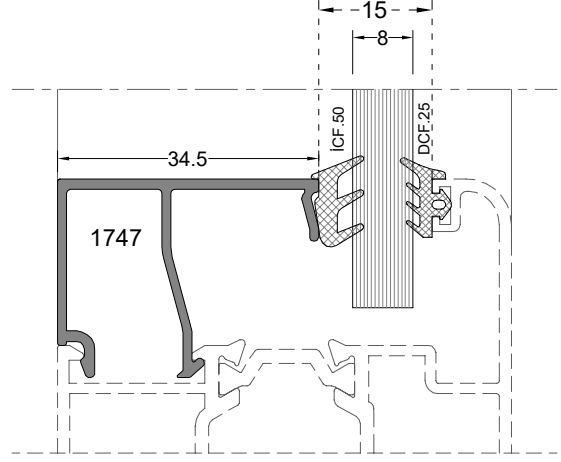
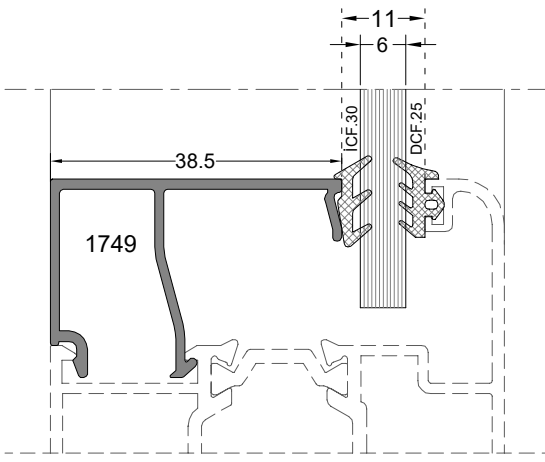
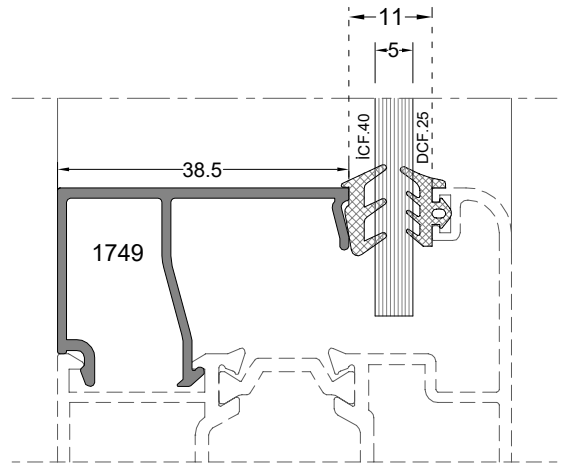
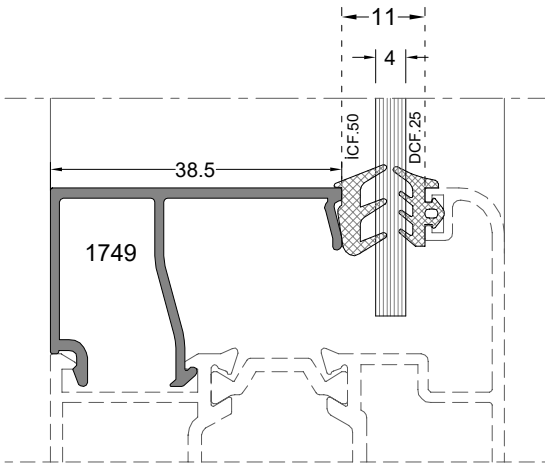

\*\* Her profil için minimum sipariş 300 kg'dır.  
\*\* Minimum order quantity is 300 kg per profile.



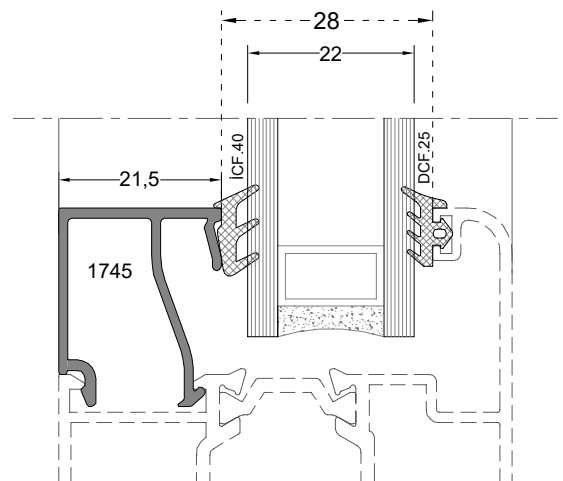
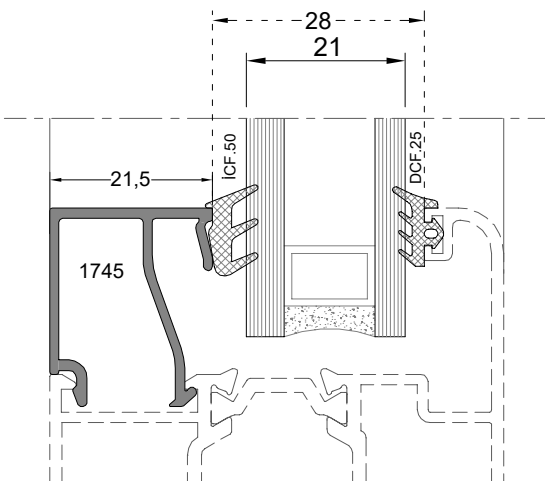
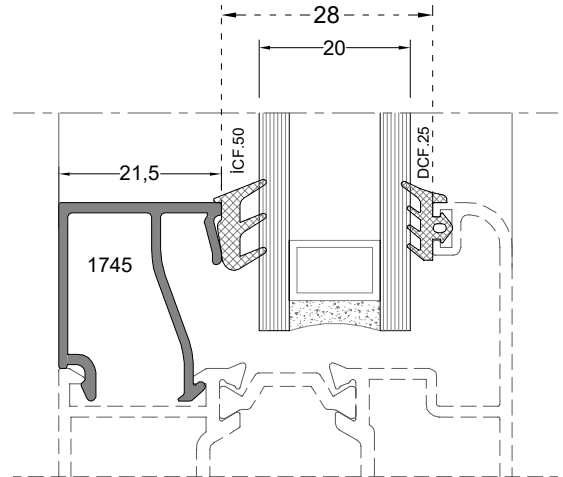
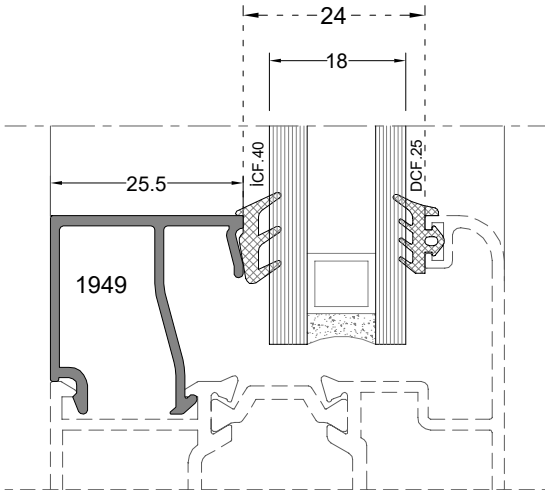
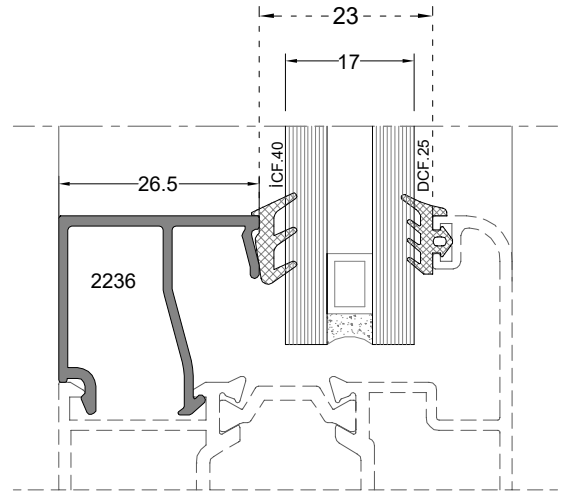
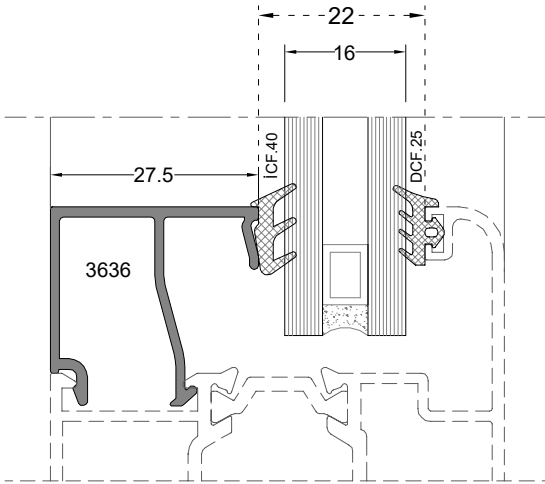
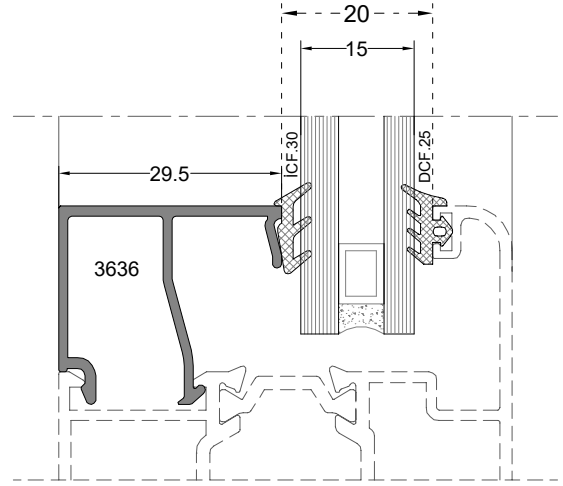
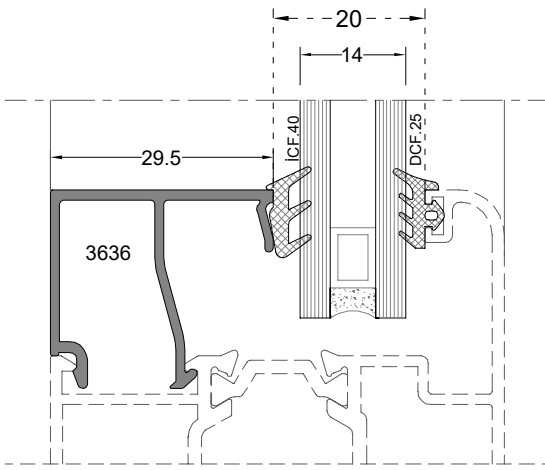

\*\* Her profil için minimum sipariş 300 kg'dır.  
\*\* Minimum order quantity is 300 kg per profile.

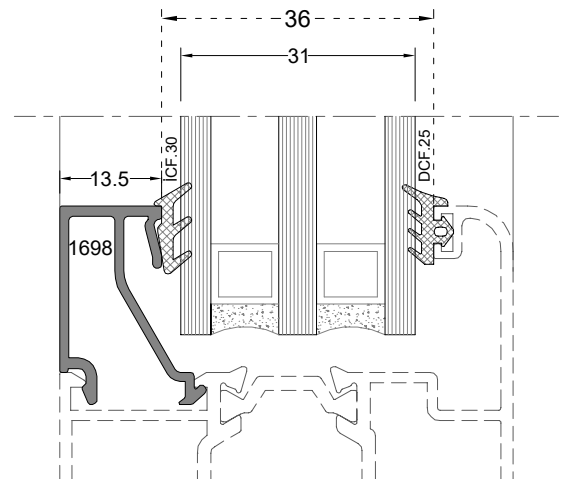
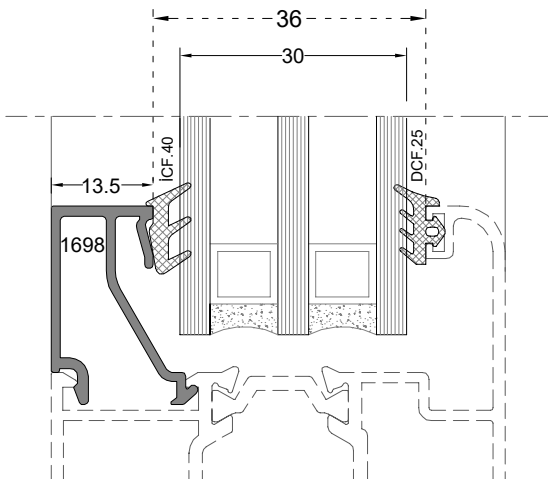
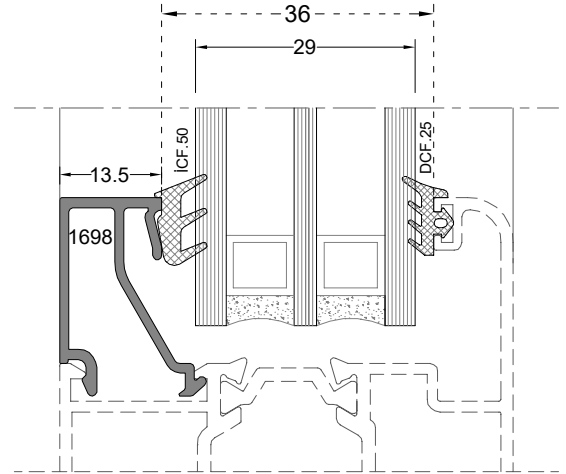
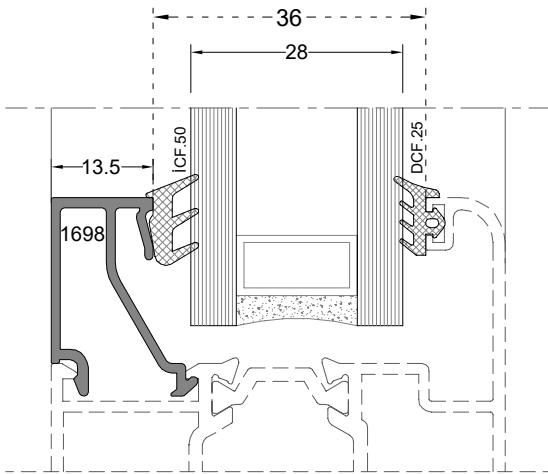
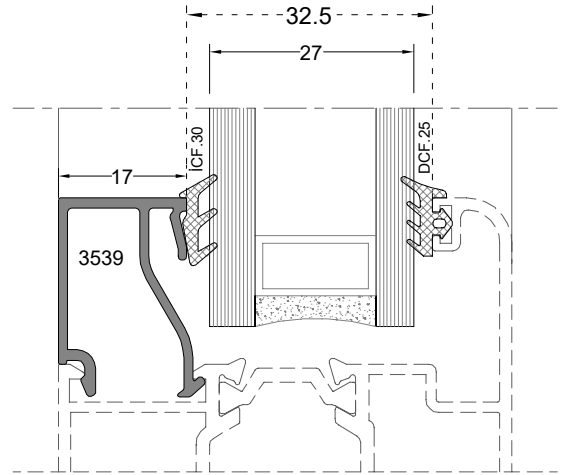
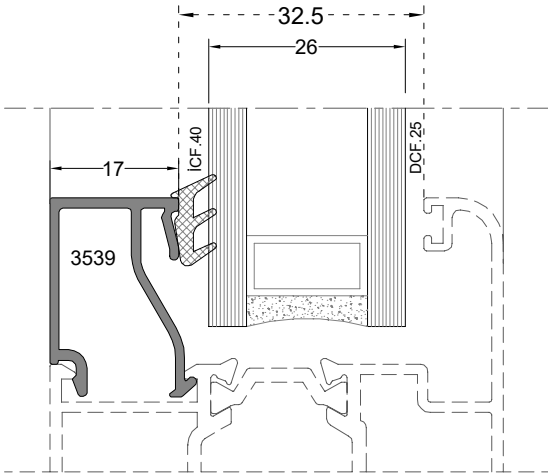
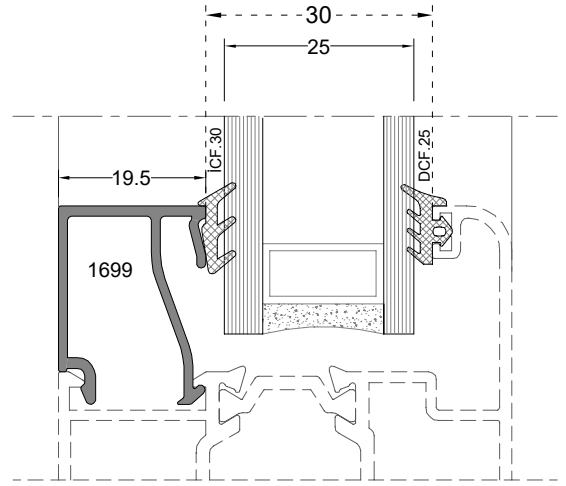
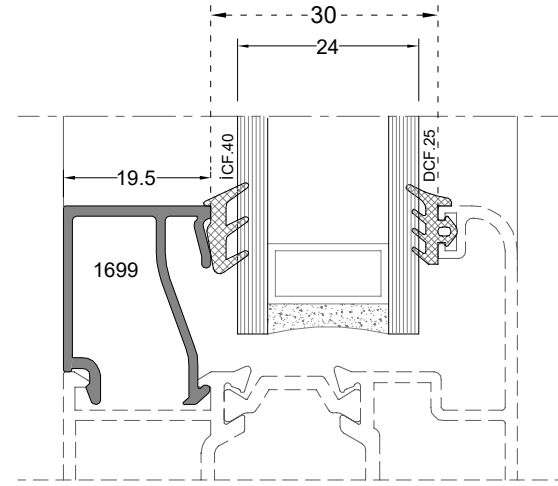

\*\* Her profil için minimum sipariş 300 kg'dır.  
\*\* Minimum order quantity is 300 kg per profile.

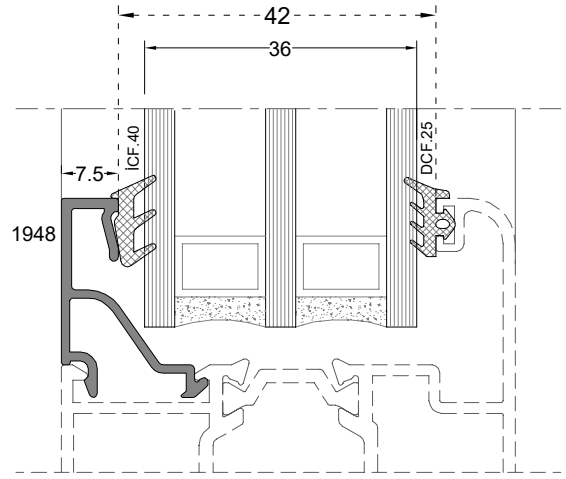
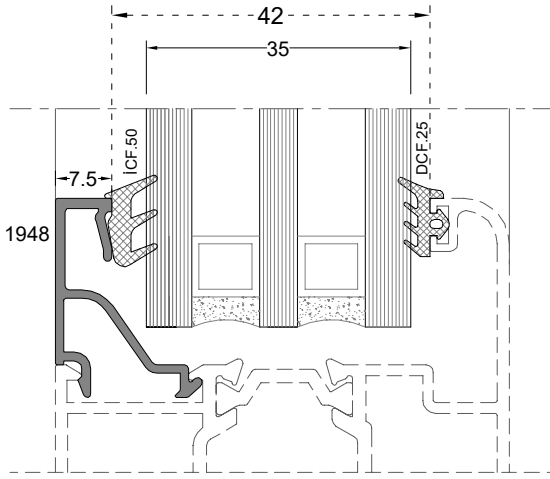

**AÇILIM TIPLERİ**  
OPENING TYPES

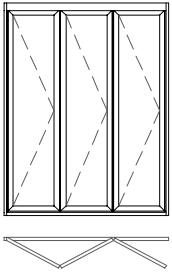

3+0 (3+3)

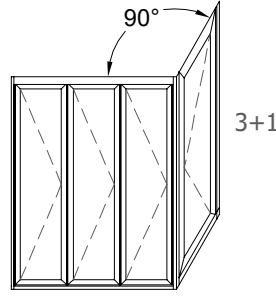

3+1

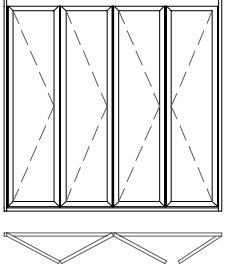
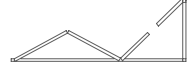

3+1=4

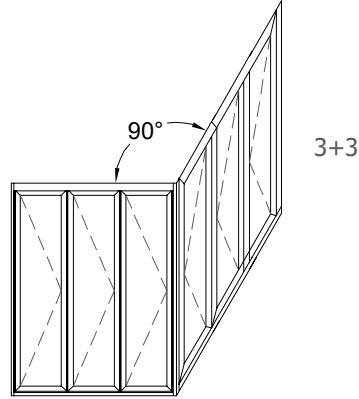

3+3

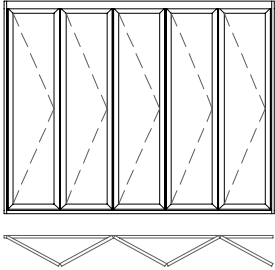
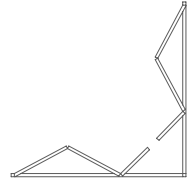

5+0 (5+5)

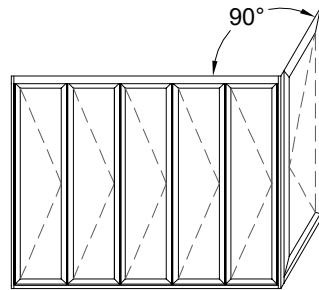

5+1

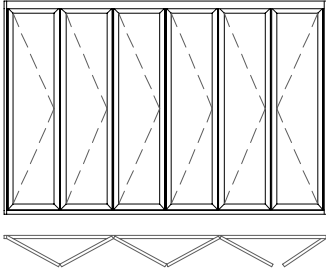
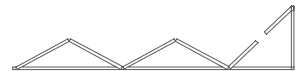

5+1=6

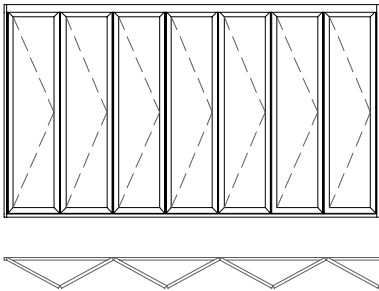

7+0 (7+7)

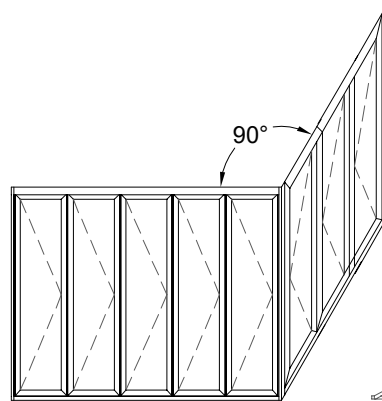

5+3

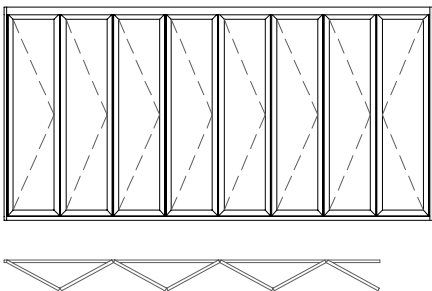
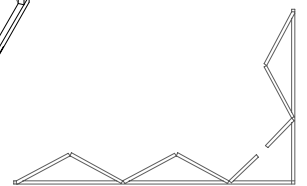

7+1=8



\*\* Her profil için minimum sipariş 300 kg'dır.  
\*\* Minimum order quantity is 300 kg per profile.

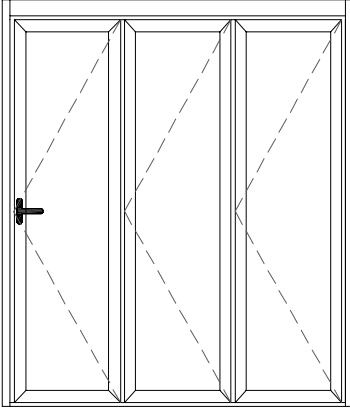

(3+0)

(3+0)

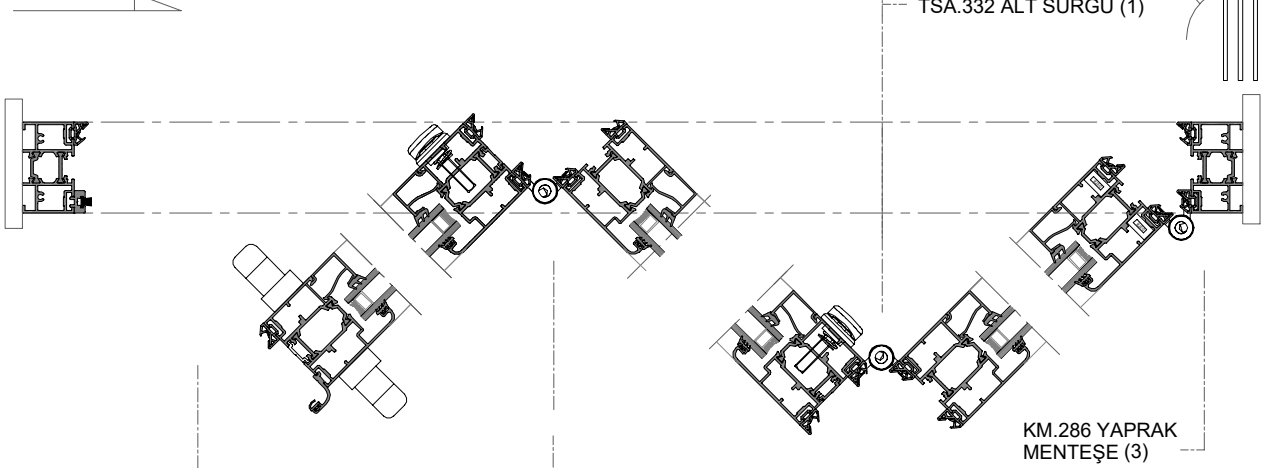

- KM.286 YAPRAK MENTEŞE (3)
- KTS.310 ÇİFT YÖNLÜ KİLİTLEME KOLU (1)
- İG.330 ÇİFT YÖNLÜ İSP. GÖVDESİ (1)
- 8241 TİJ PROFİLİ
- ÇK.305 ÇEKME KOL (1)
- TSÜ.331 ÜST SÜRGÜ (1)
- TSA.332 ALT SÜRGÜ (1)

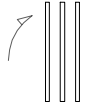

KM.286 YAPRAK  
MENTEŞE (3)

RMS.320 RULMANLI  
MENTEŞE ÜST (1)

RML.327 RULMANLI  
MENTEŞE ALT (1)

KM.286 YAPRAK  
MENTEŞE (1)

RK.291 PENCERE KOLU (1)

İG.330 ÇİFT YÖNLÜ İSP. GÖVDESİ (1)

8241 TİJ PROFİLİ

TSÜ.331 ÜST SÜRGÜ (1)

TSA.332 ALT SÜRGÜ (1)

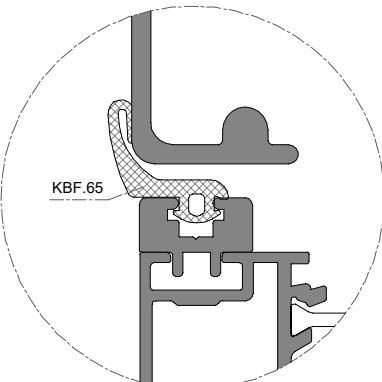
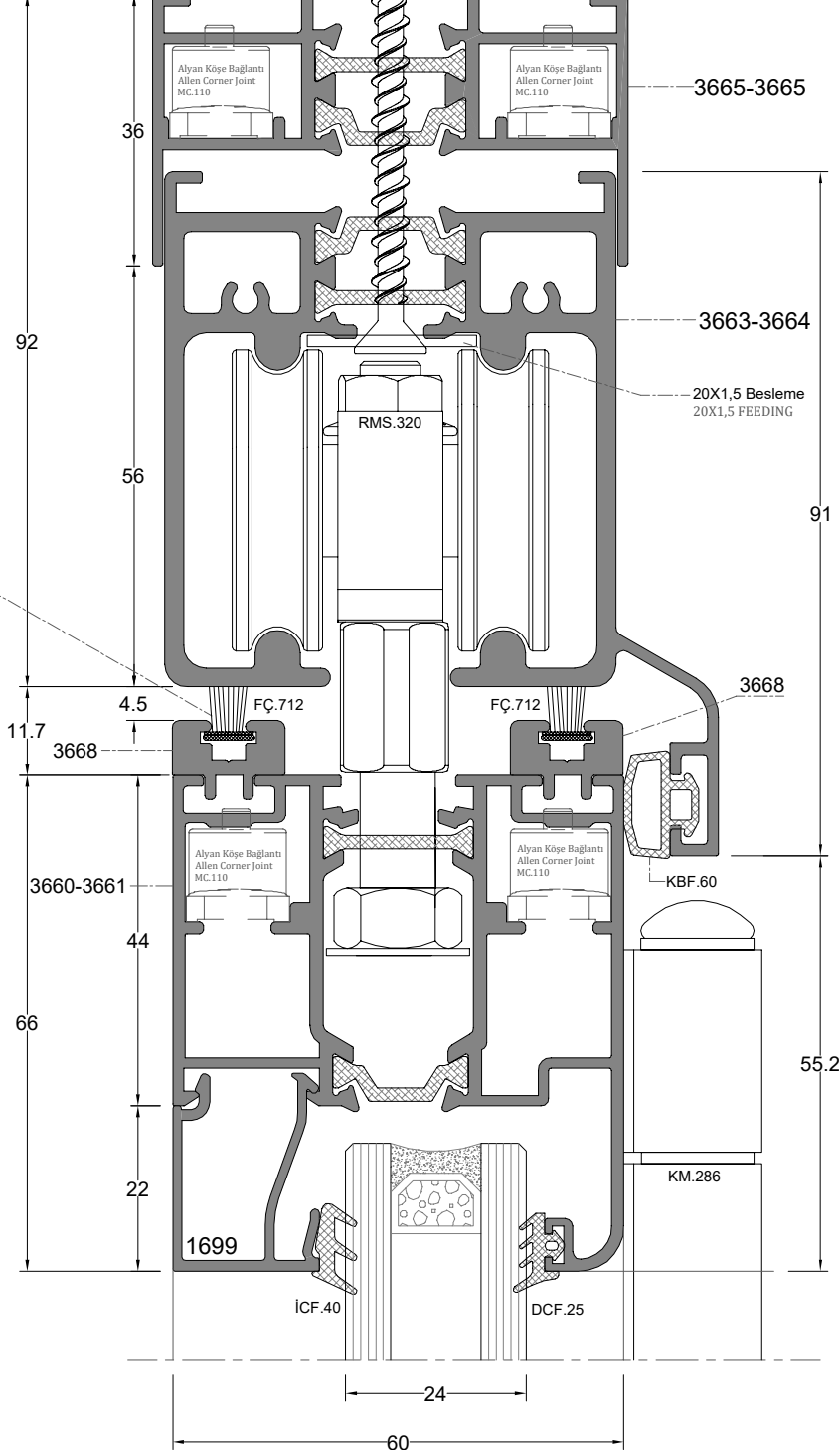
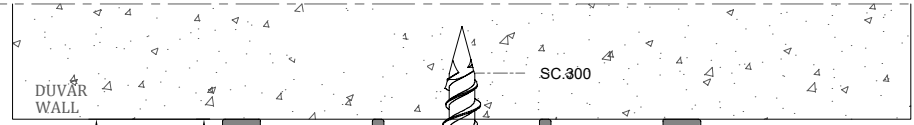
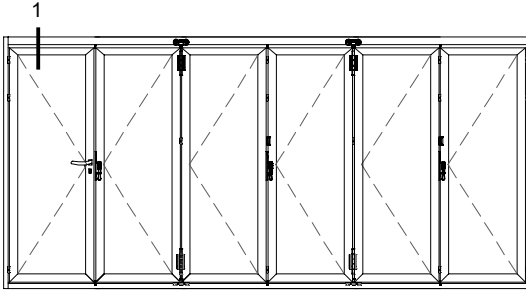

★ FÇ.712 fırça fitiline alternatif olarak KBF.65 EPDM conta da kullanılabilir.  
KBF.65 EPDM gasket can be used as an alternative to FÇ.712 weather strip.

**D-1**

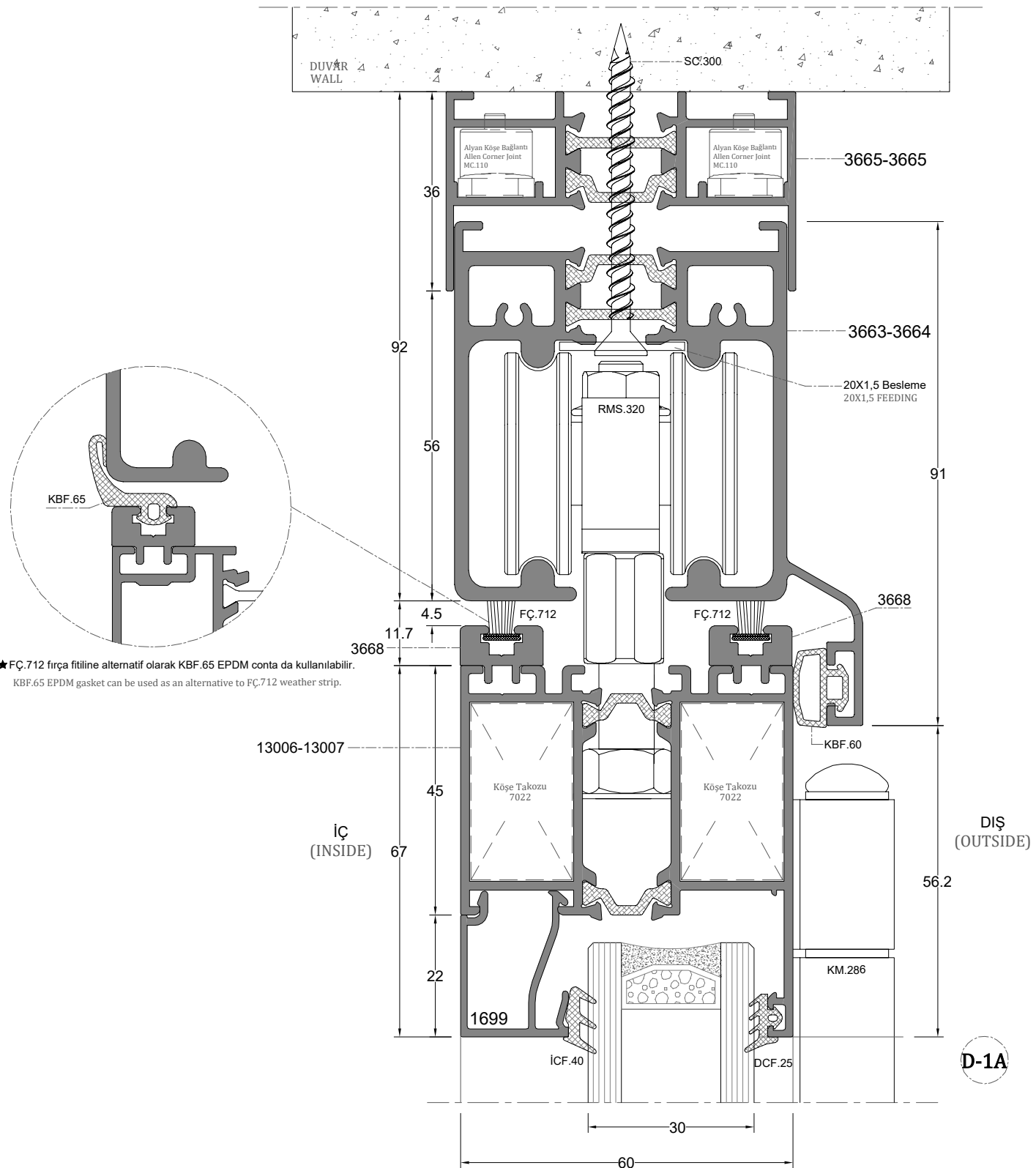
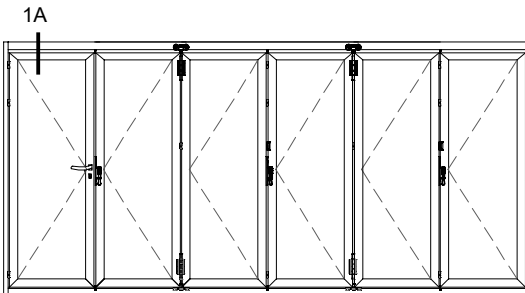

★FÇ.712 fırça fitiline alternatif olarak KBF.65 EPDM conta da kullanılabilir.  
KBF.65 EPDM gasket can be used as an alternative to FÇ.712 weather strip.

**D-1A**

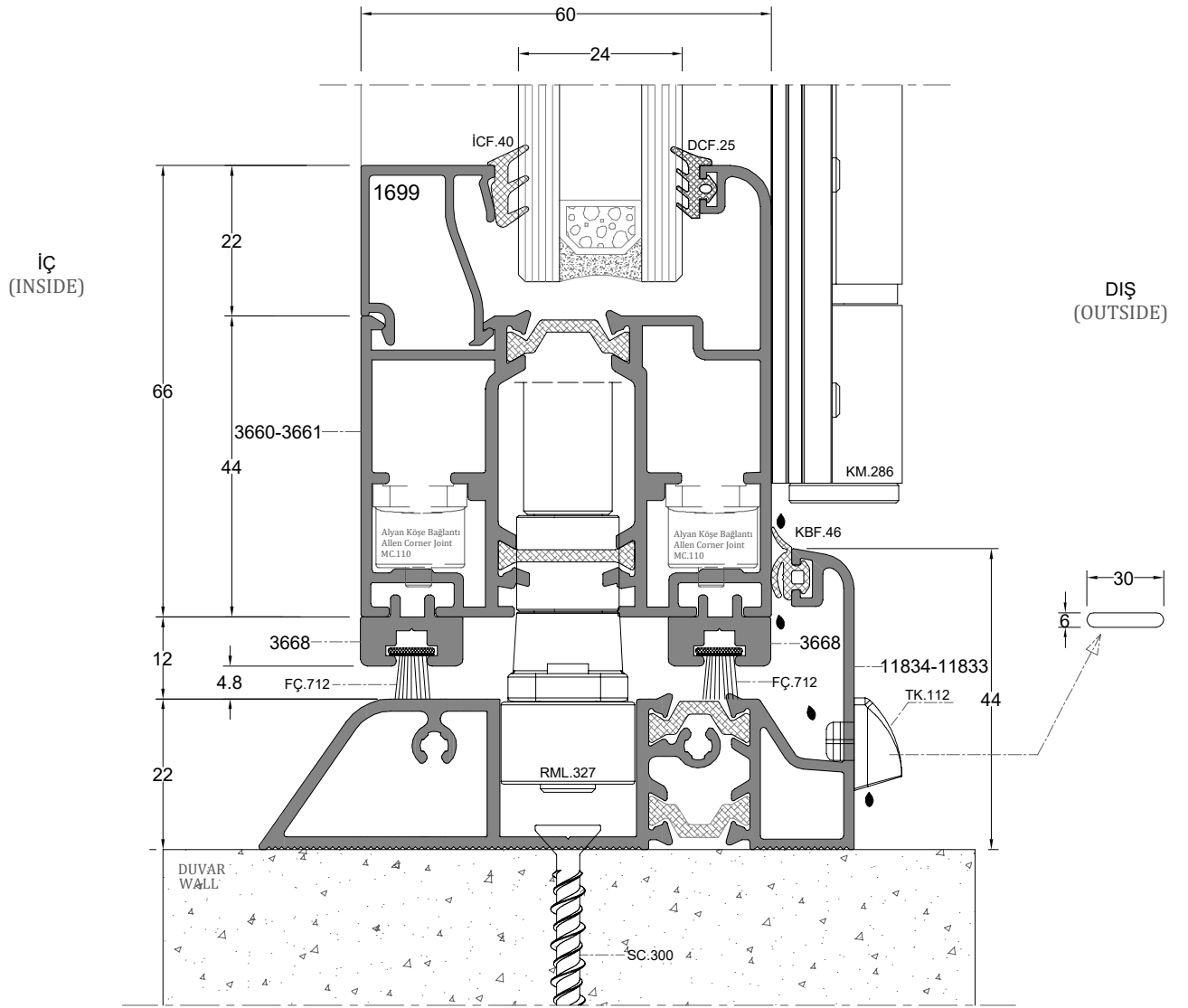
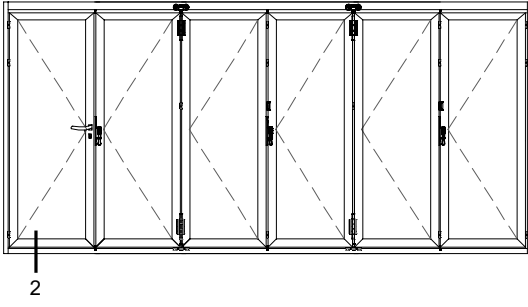



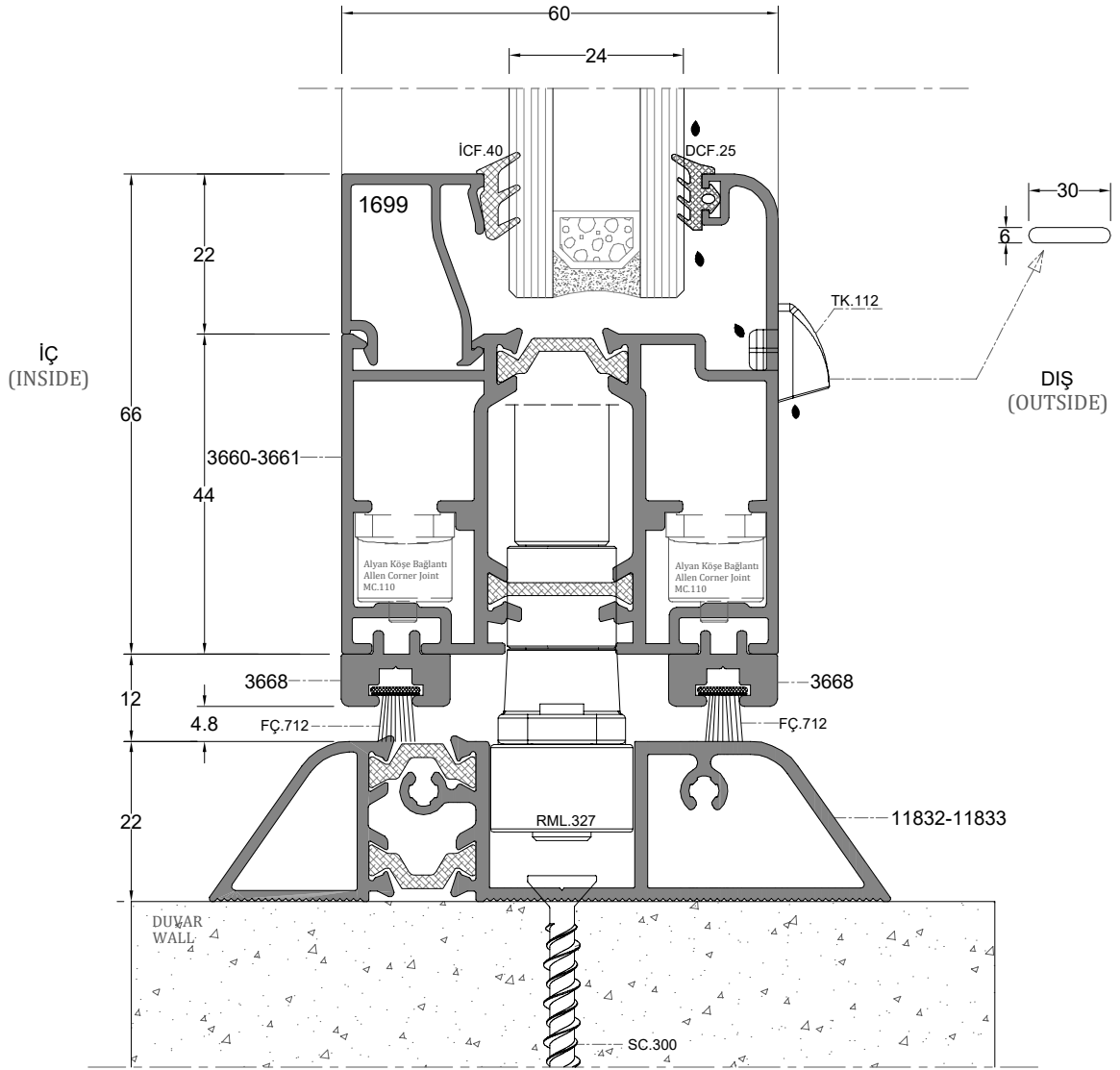
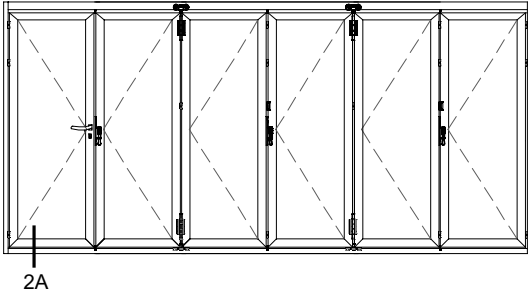

D-2A

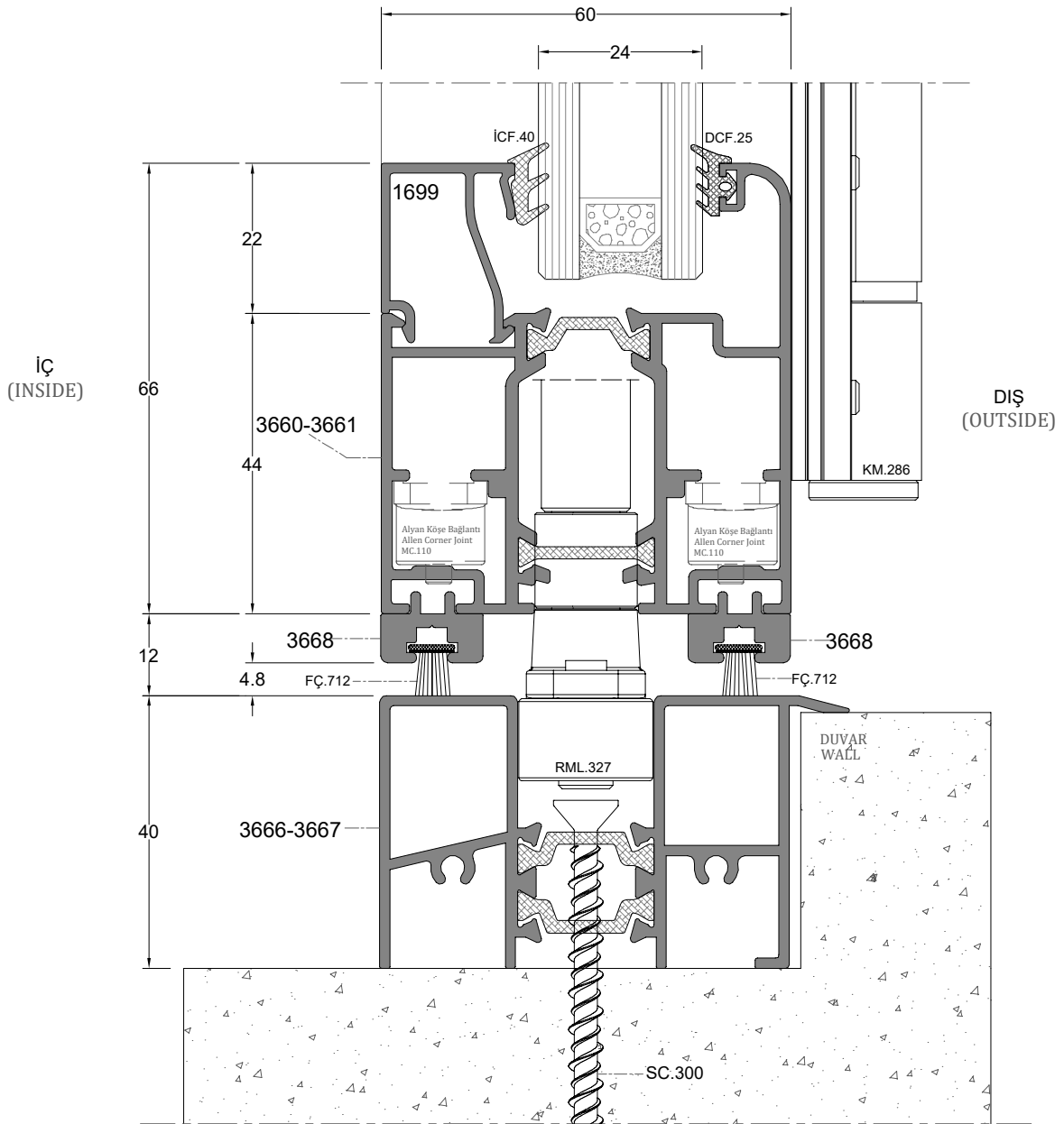
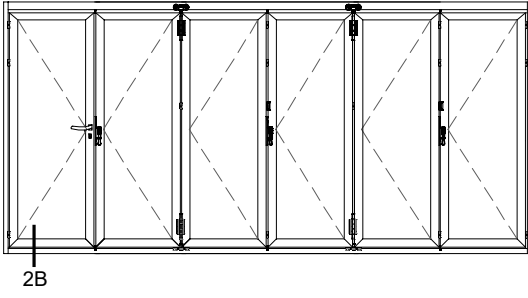

D-2B

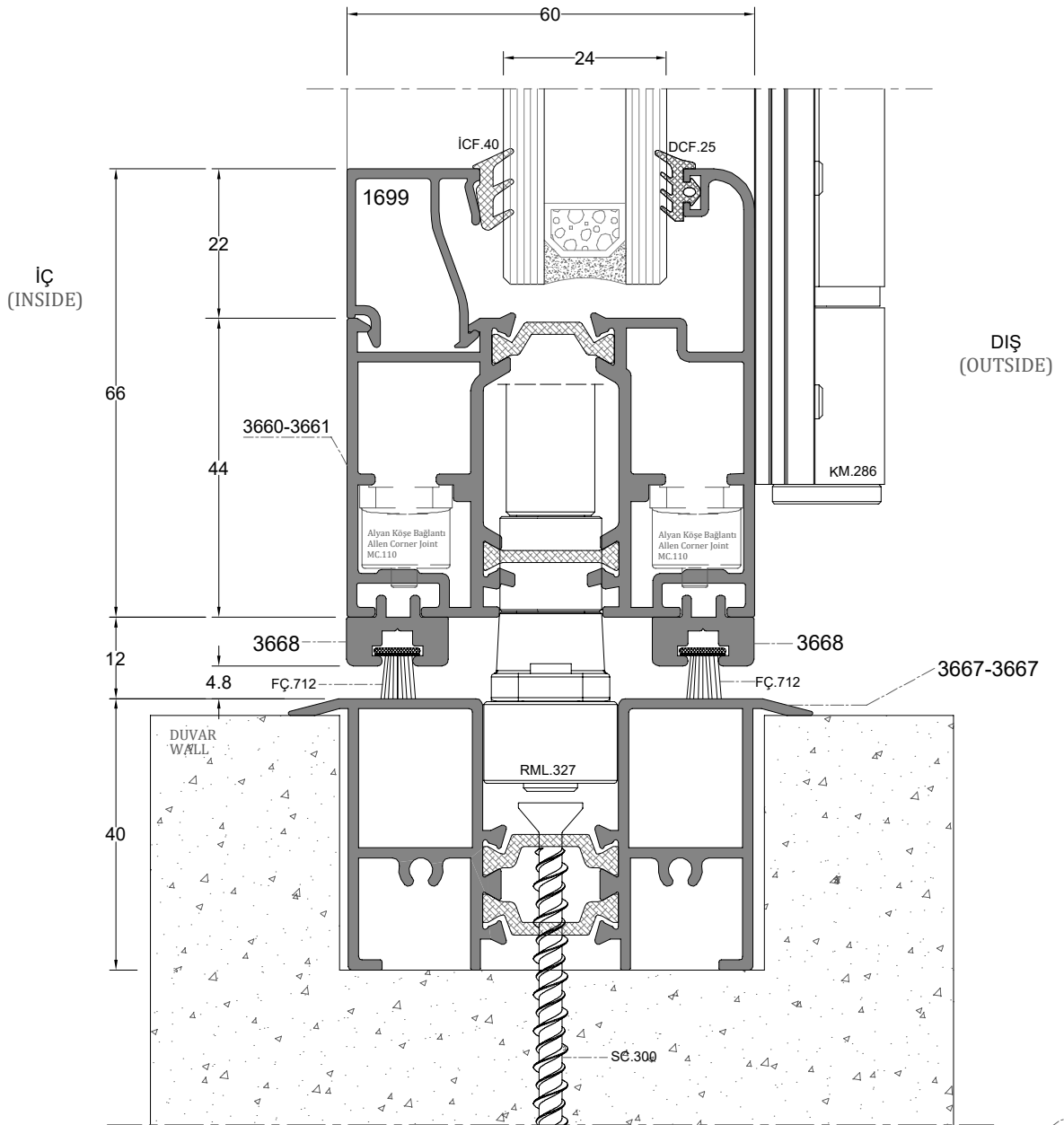
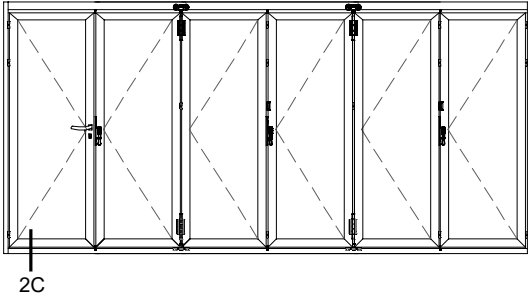

D-2C

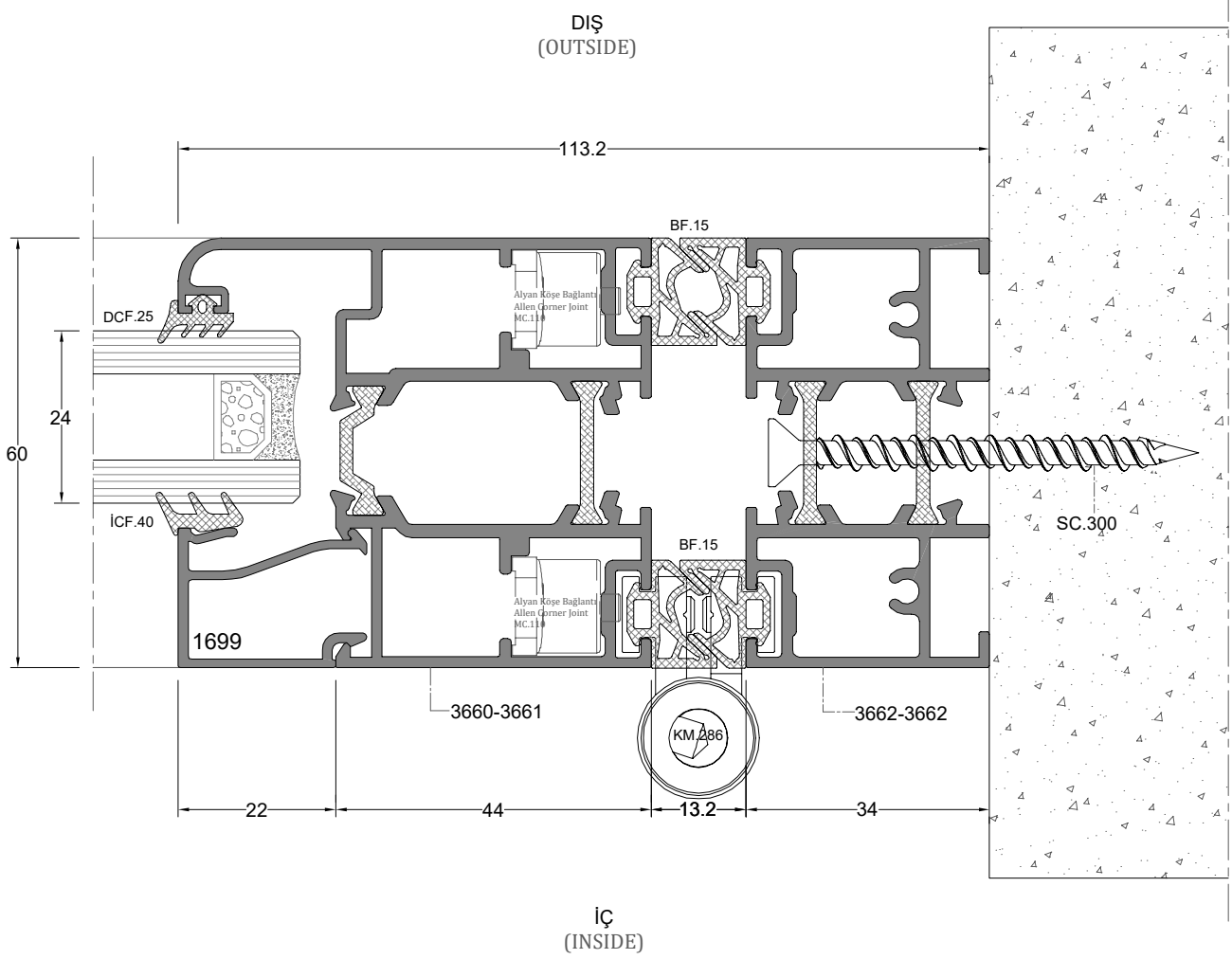
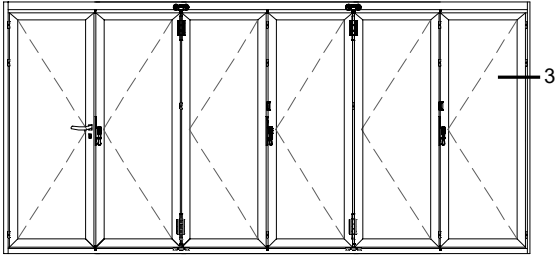

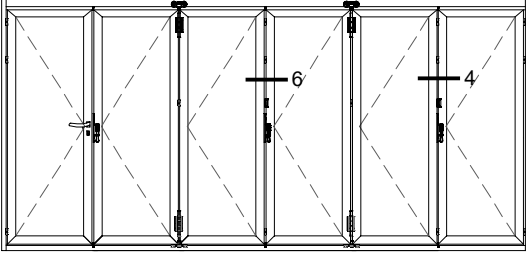

DIŞ  
(OUTSIDE)

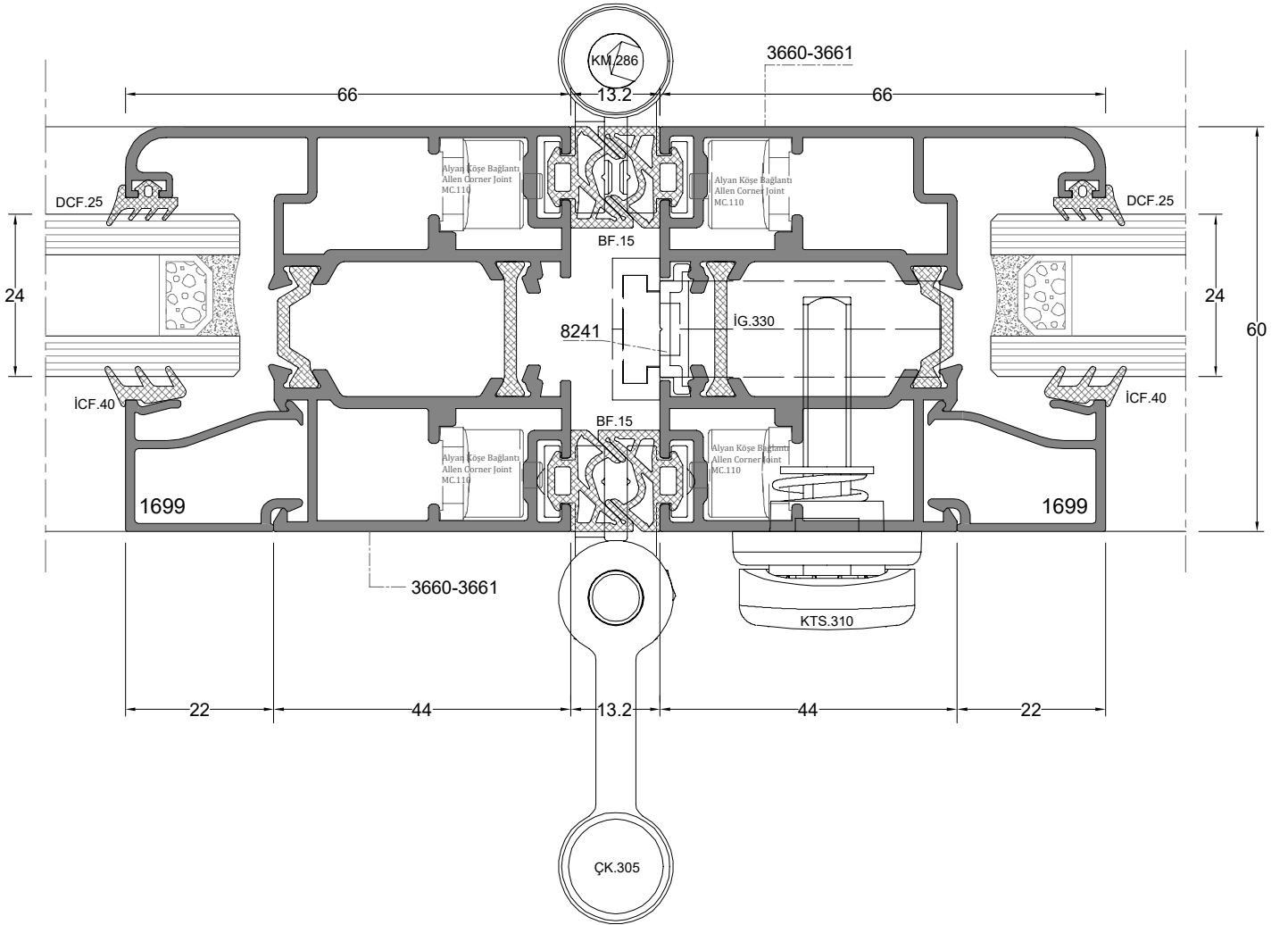

D-6

D-4

İÇ  
(INSIDE)

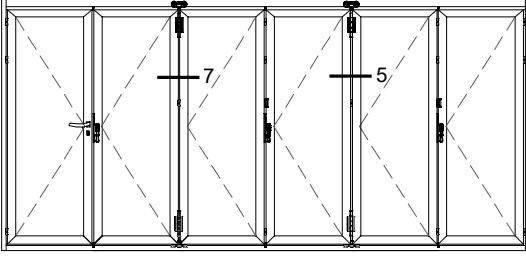

DIŞ  
(OUTSIDE)

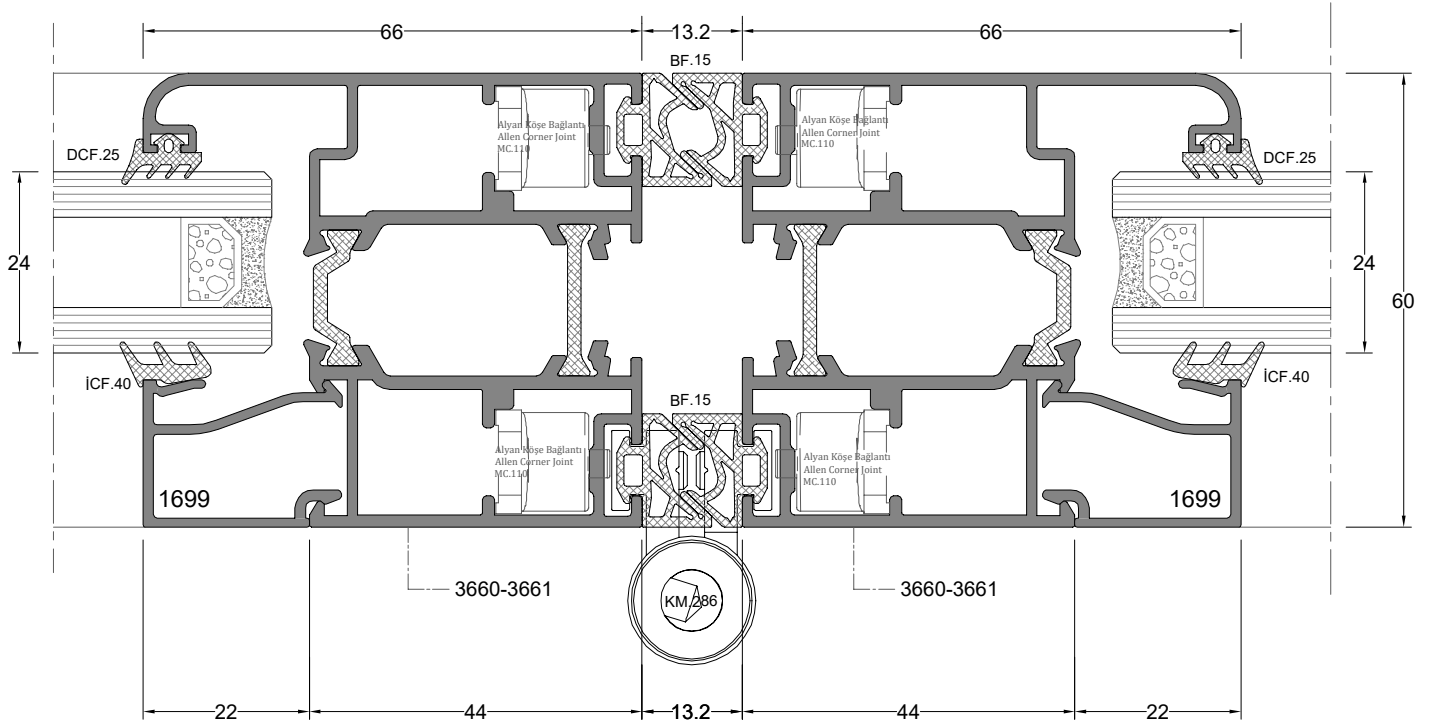

İÇ  
(INSIDE)

D-7

D-5

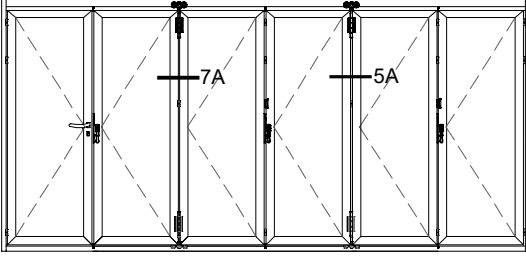

DIŞ  
(OUTSIDE)

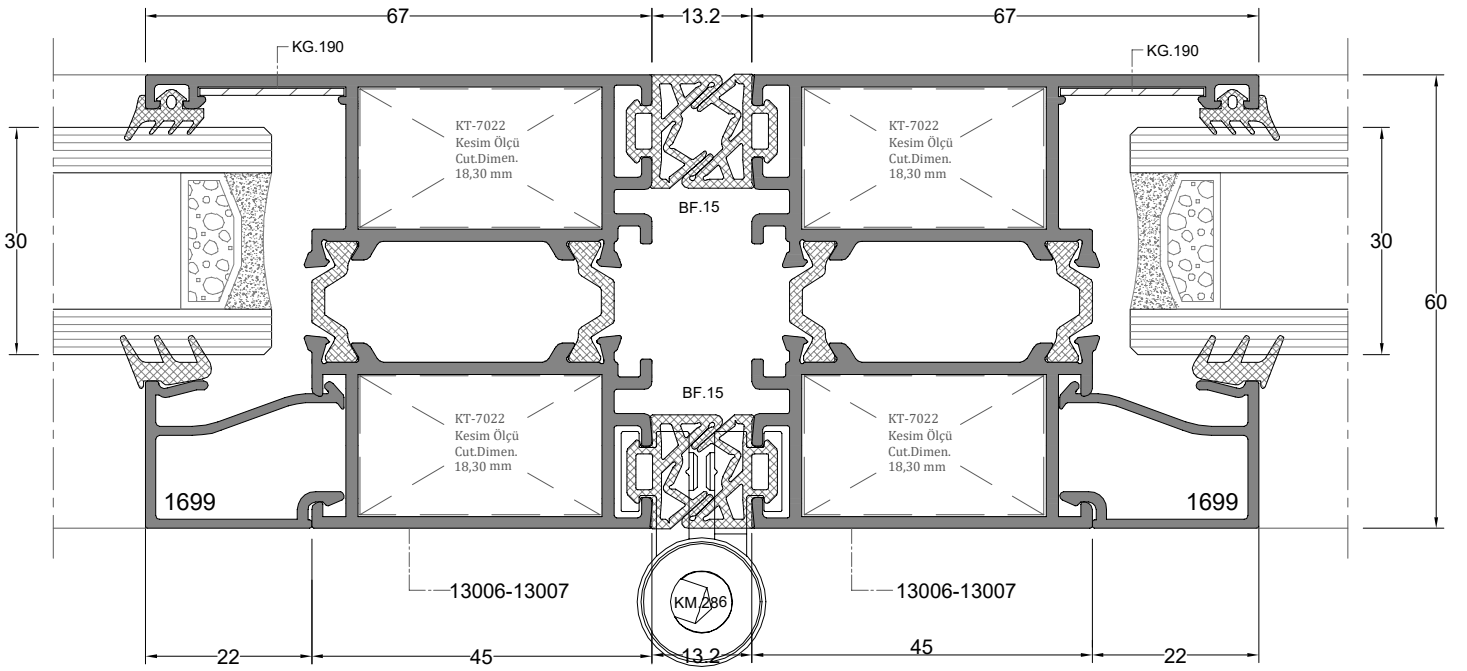

İÇ  
(INSIDE)

D-7A

D-5A

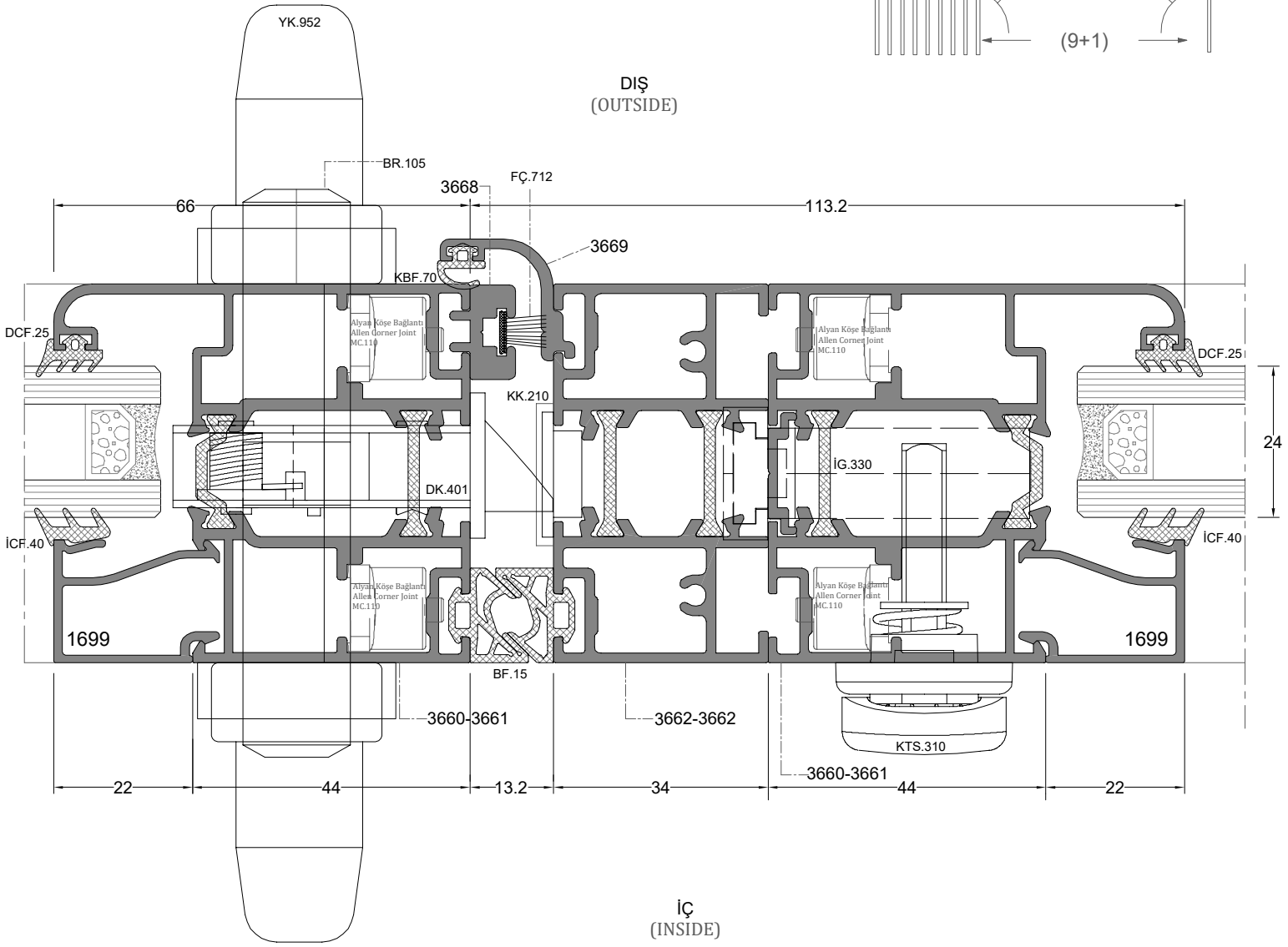
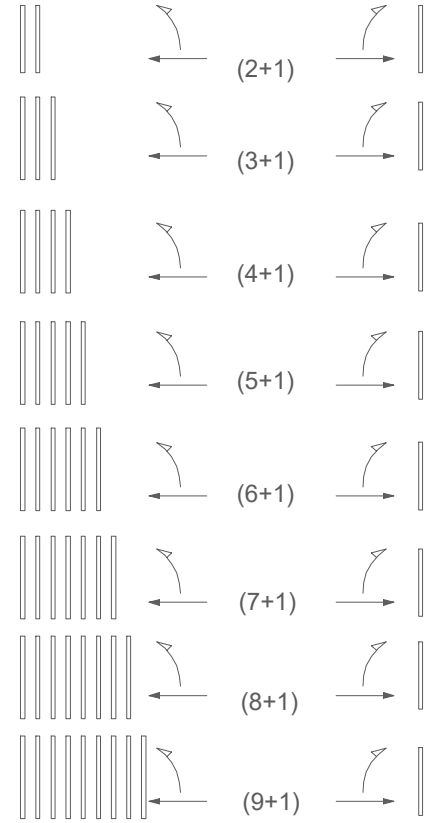
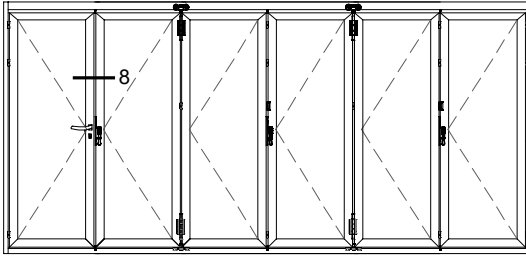



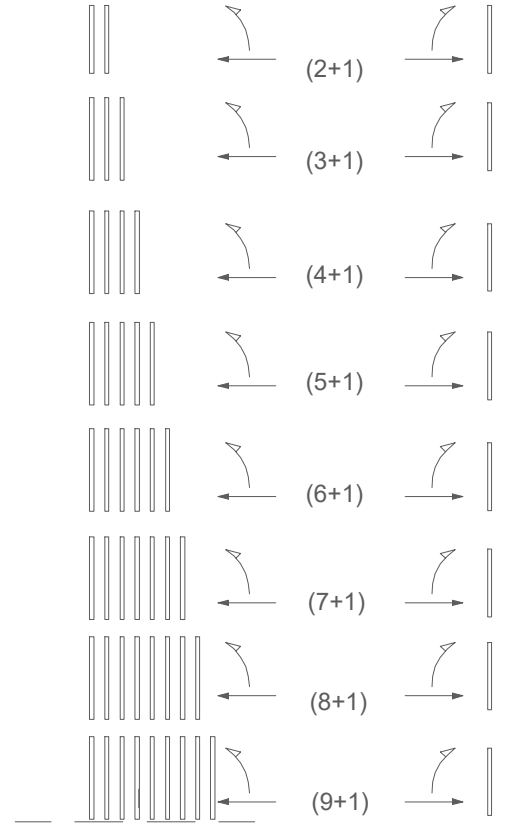
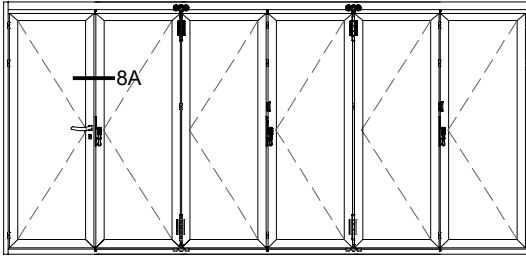

DIŞ  
(OUTSIDE)

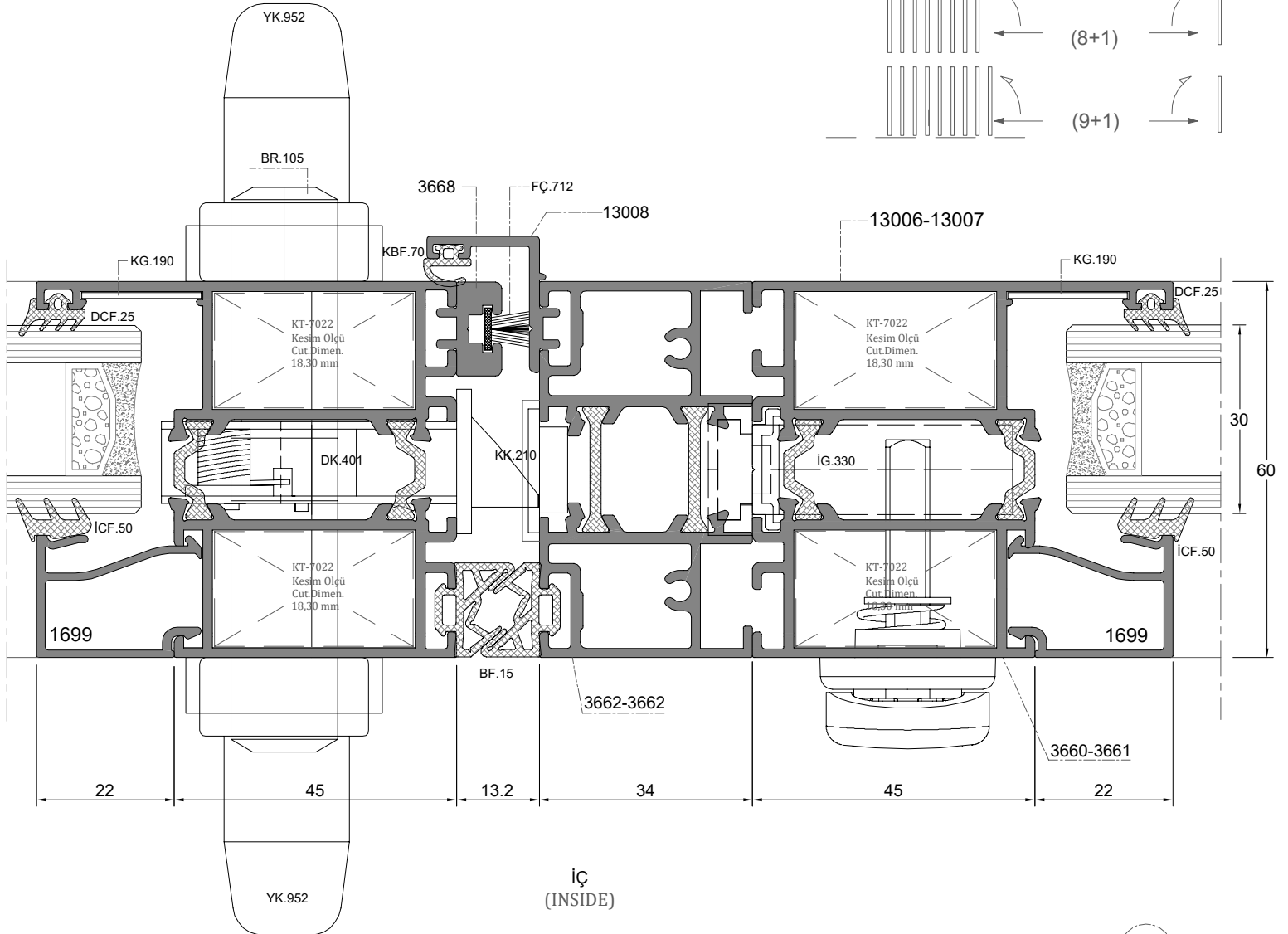

İÇ  
(INSIDE)

D-8A

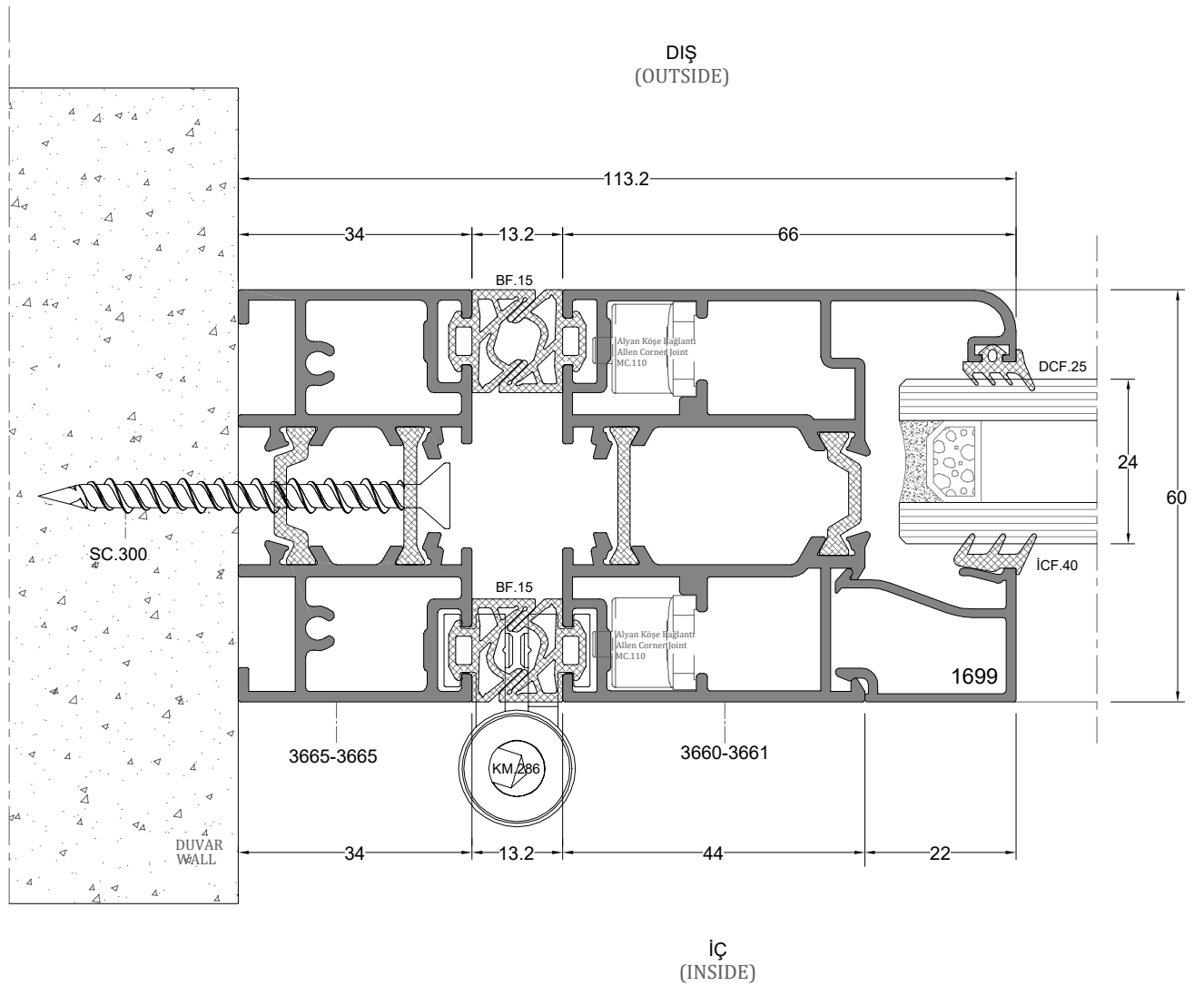
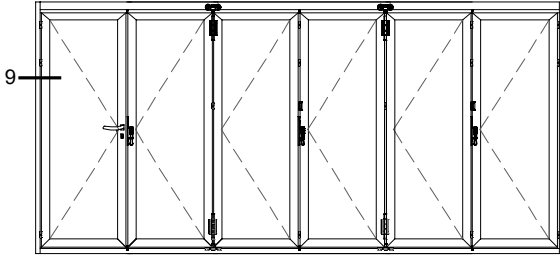

D-9

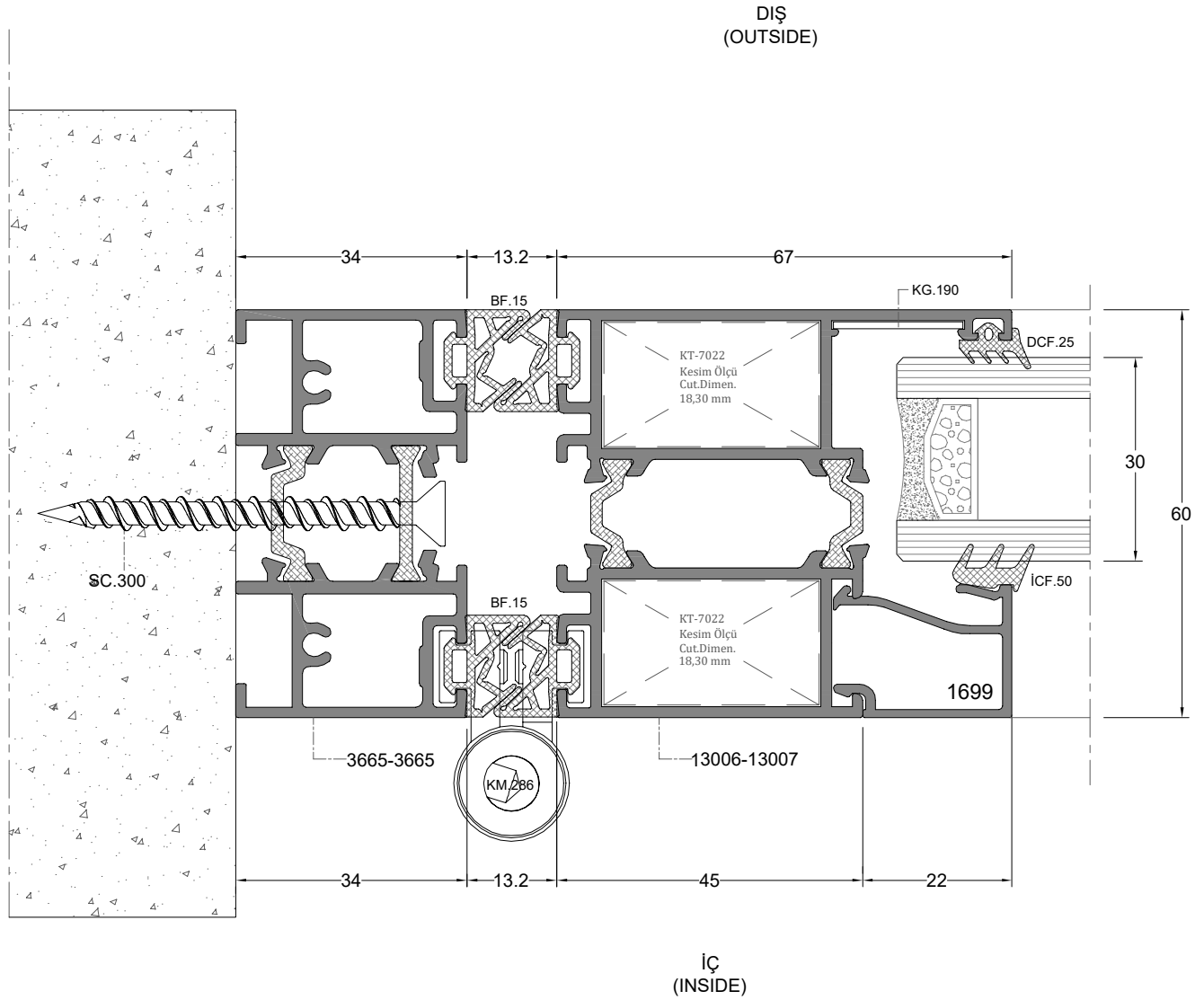
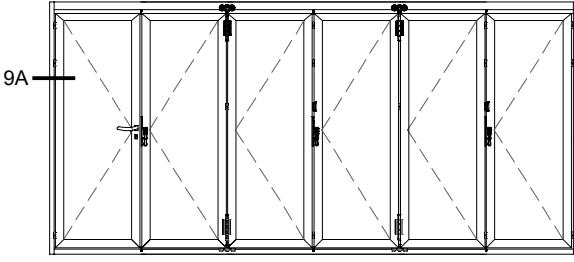

D-9A

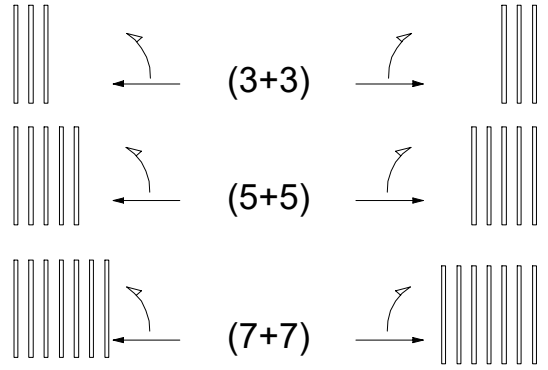
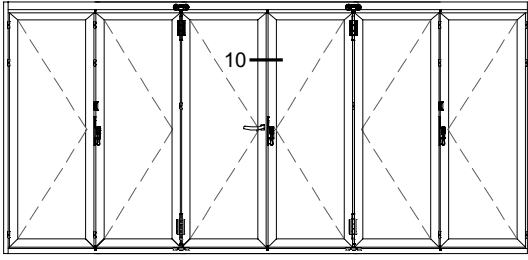

DIŞ  
(OUTSIDE)

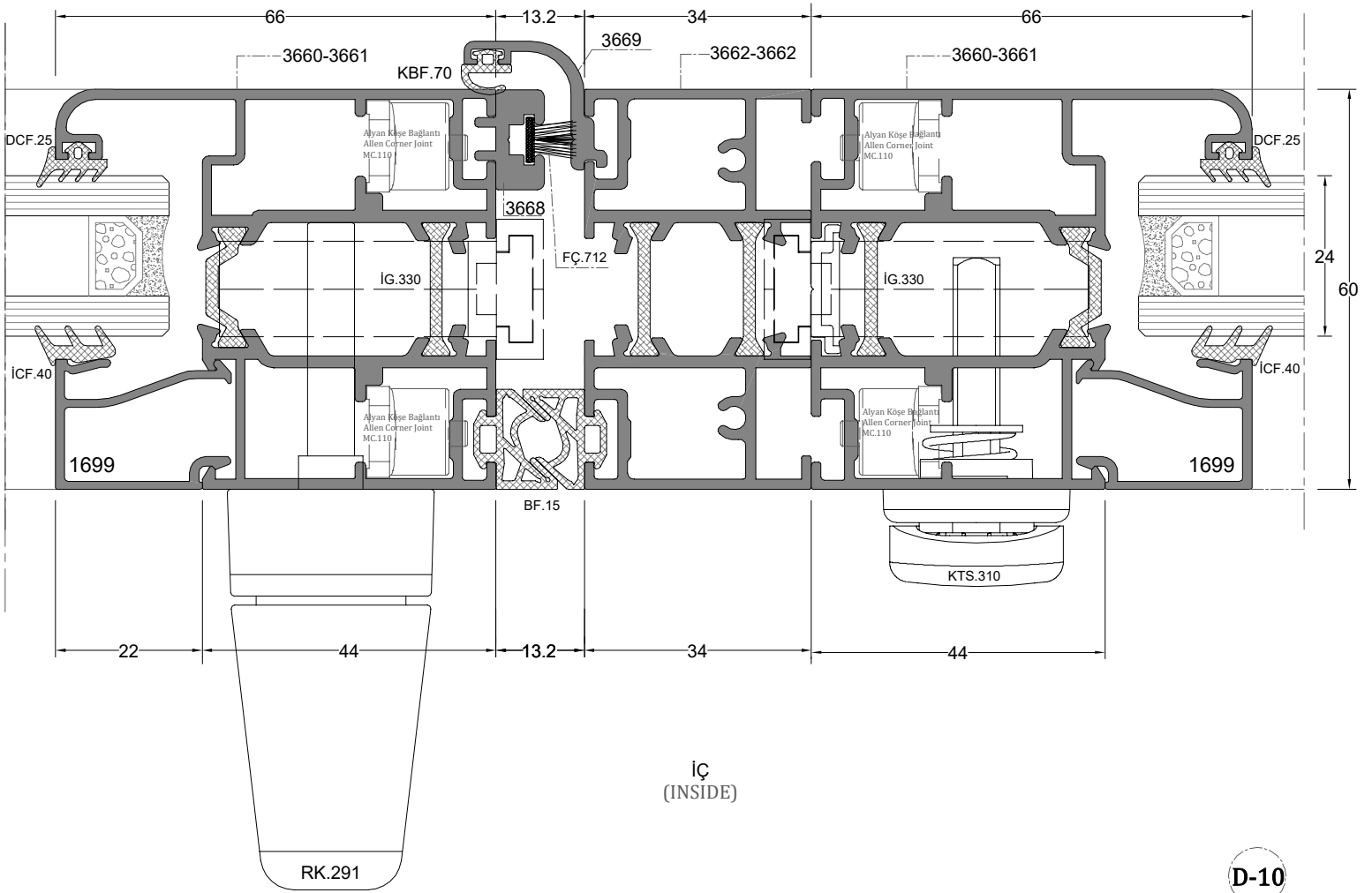

D-10

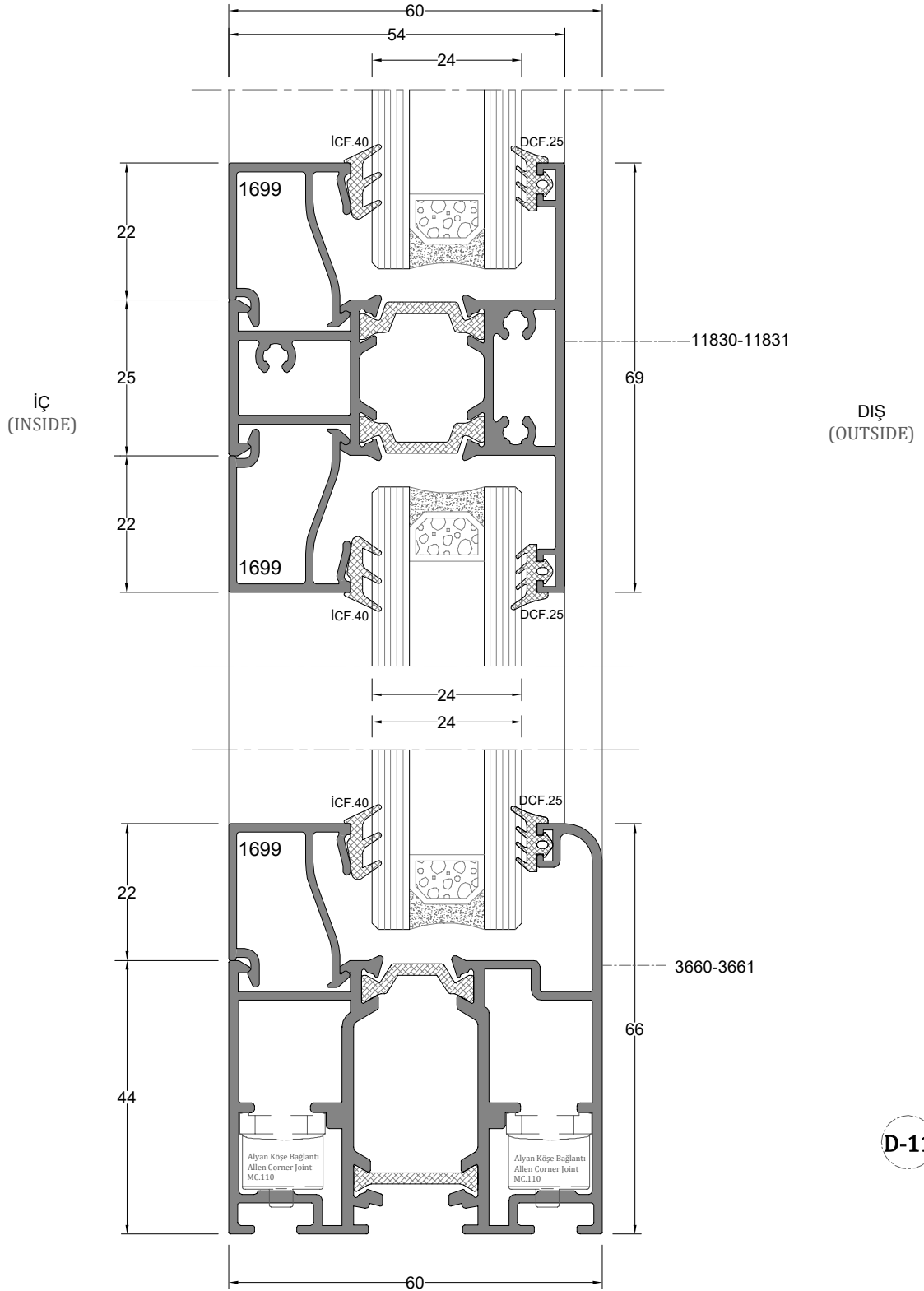
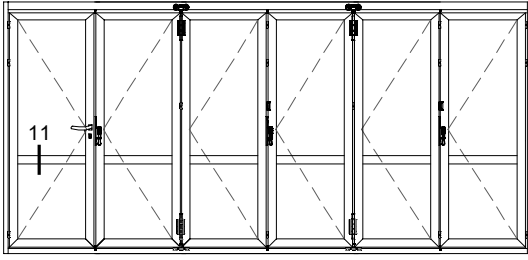

3+0  
5+0  
7+0

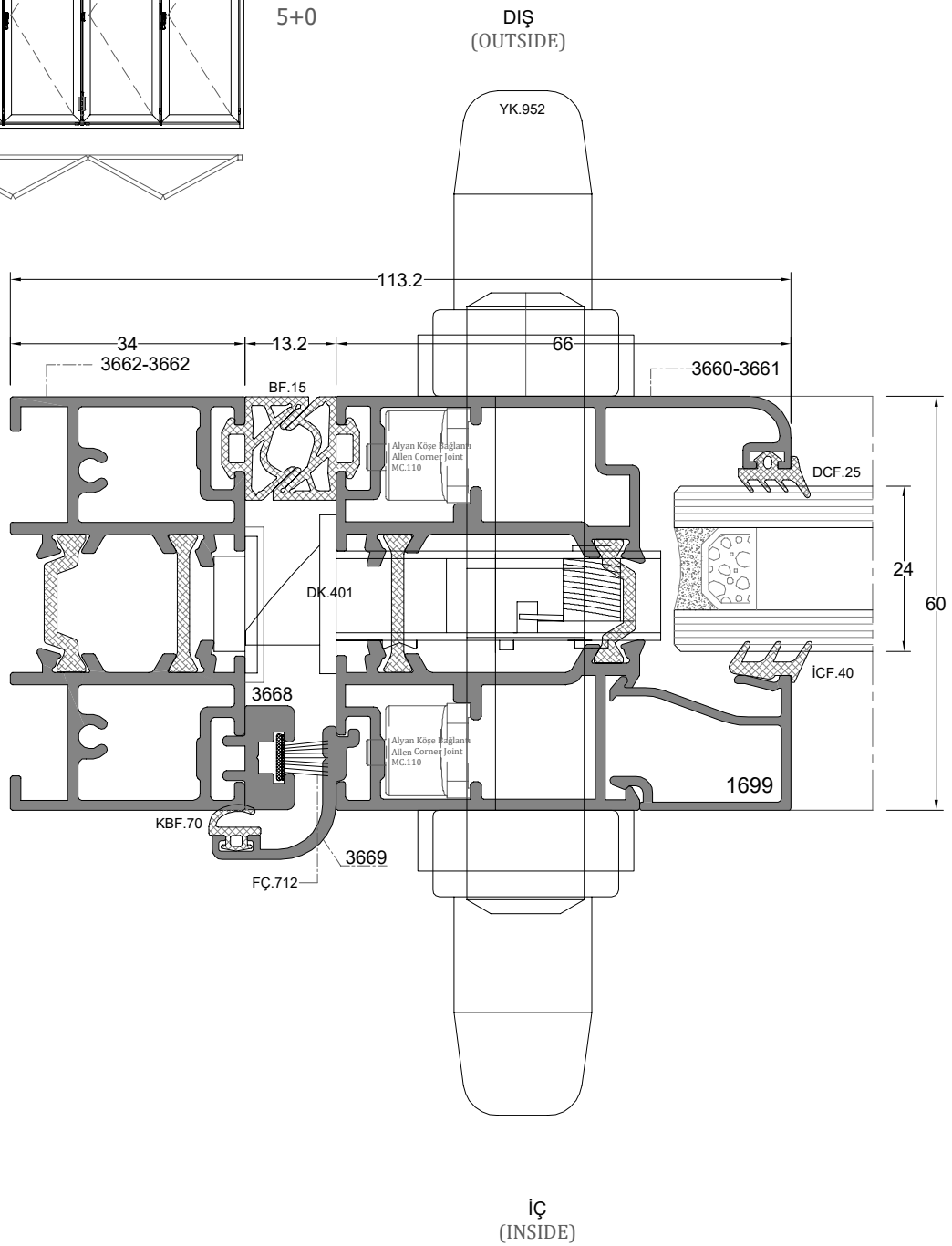
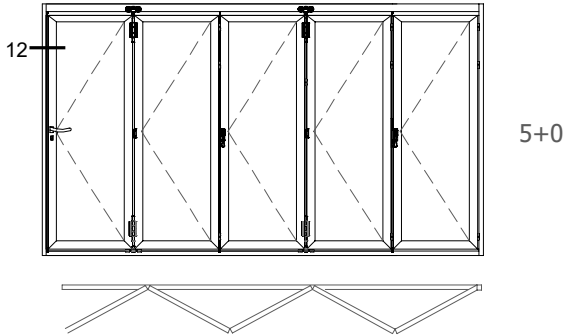
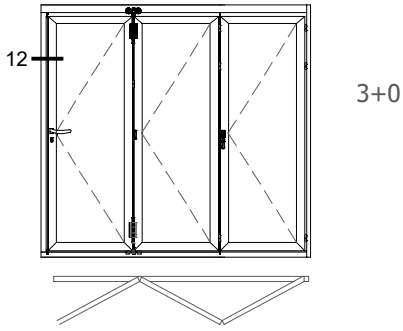

D-12

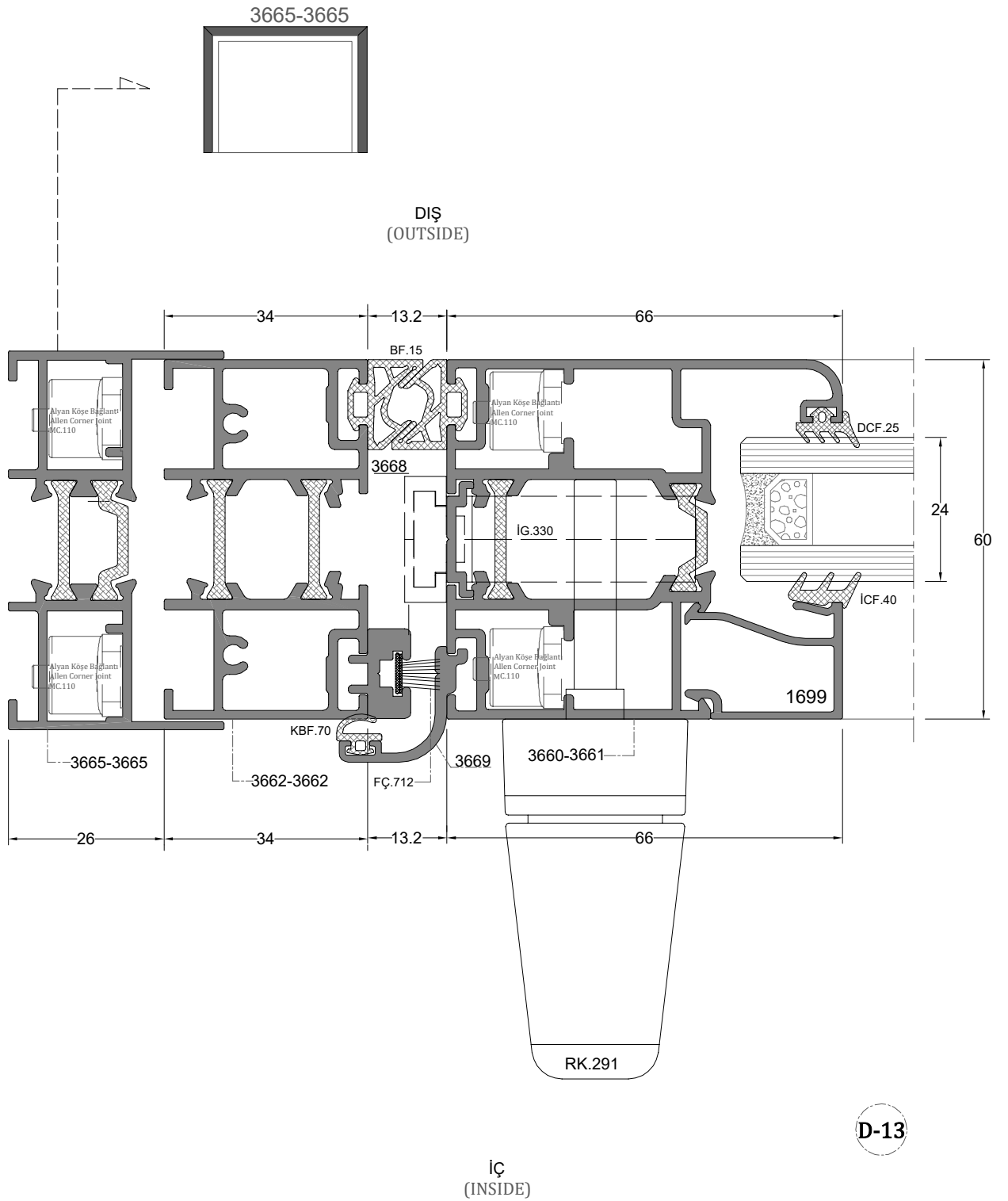
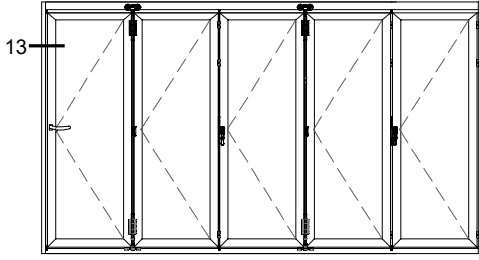

D-13

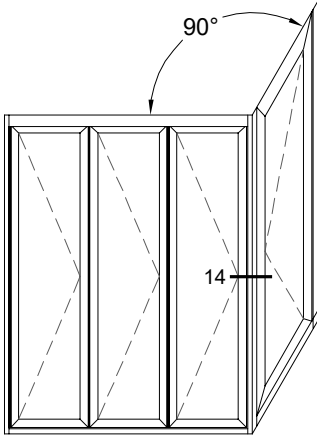

DIŞ  
(OUTSIDE)

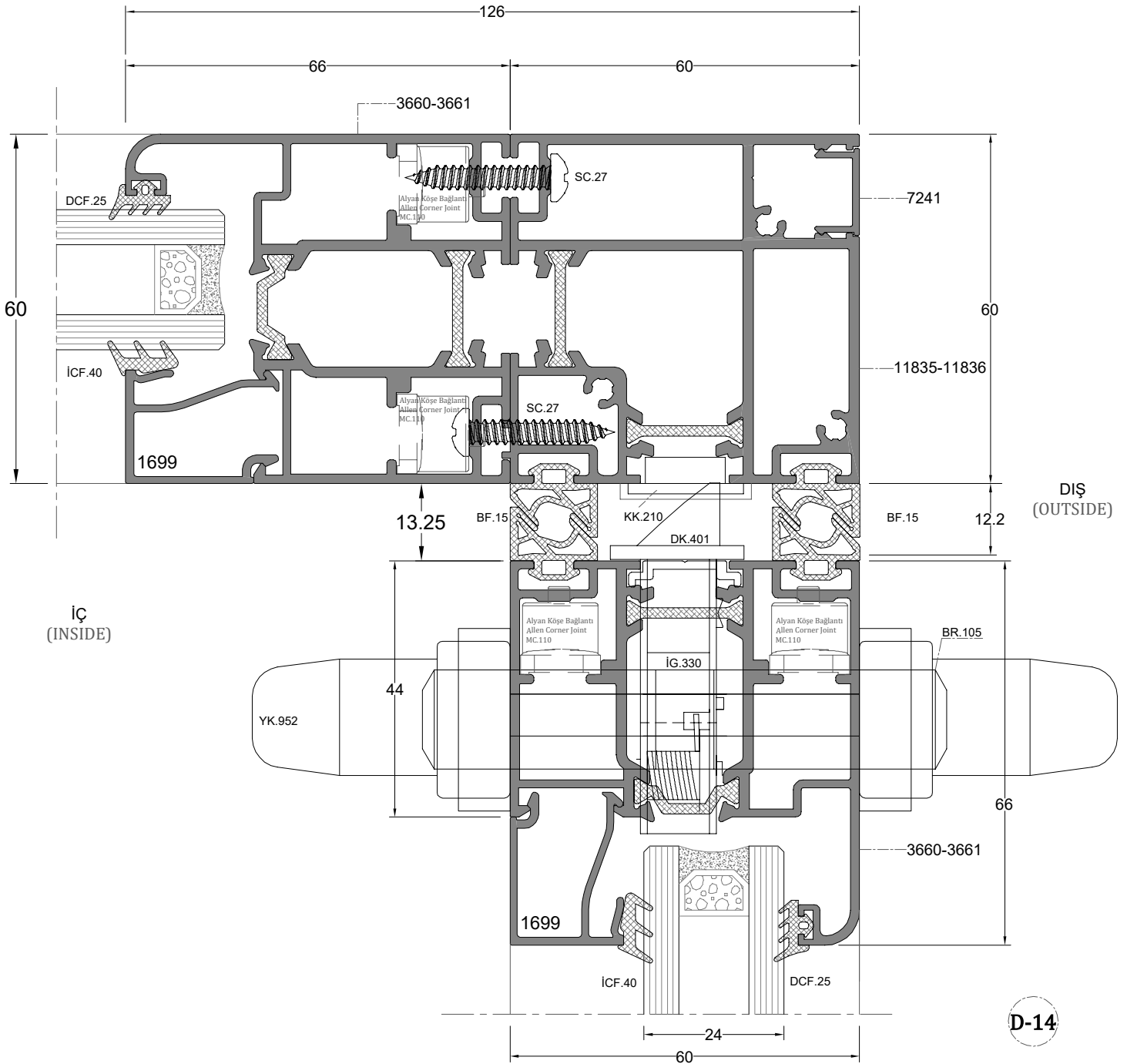



**YÜKSEK EŞİKLİ SİSTEM KESİM ÖLÇÜSÜ**

PROFILE CUT DIMENSION FOR HIGH THRESHOLD SYSTEM

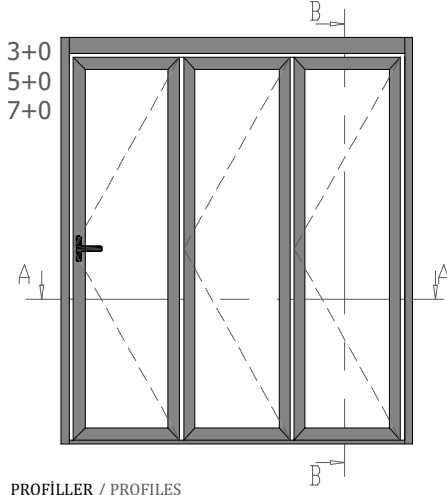

PROFİLLER / PROFILES

NOT : A= Kanat Adeti

Kod Code	Çizim Drawing	Kesim Cut	Miktar Quantity	Ölçüler Dimensions
3662-3662 Kasa Profili Frame Profile			2 Adet	H
3660-3661 Kanat Profili Sash Profile			2 x A	$\frac{L-(68+(A+1) \times 13)}{A}$
			2 x A	H-132
3666-3667 veya 3667-3667 Eşik Profili Threshold Profile			1	L-68
			1	L-68
3663-3664 Üst Kasa Profili Top Frame Profile			1	L-68
3668 Fırça Adaptör Profili Brush Adapter Profile			3 x A	Kanat Genişliği+13
			3 x A	Kanat Yüksekliği x 1
3669 Adaptör Profili Adapter Profile			1	Kanat Yüksekliği x 1

CAM / GLAZING

Kod Code	Çizim Drawing	Miktar Quantity	Ölçüler Dimensions
CAM GLAZING		A	GL = SL-102
			GH =SH-102

CAM ÖLÇÜLERİ EŞİT KABUL EDİLEREK FORMÜLE EDİLMİŞTİR.  
GLAZING DIMENSIONS ARE ASSUMED TO BE EQUAL.

**A-A KESİTİ**

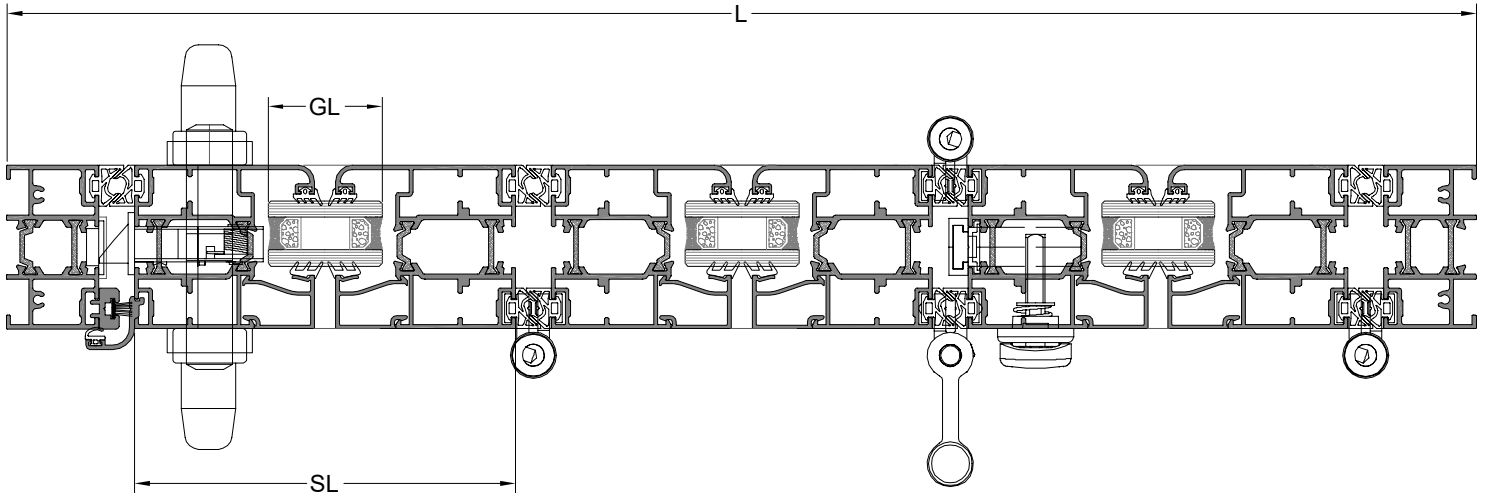

**B-B KESİTİ**

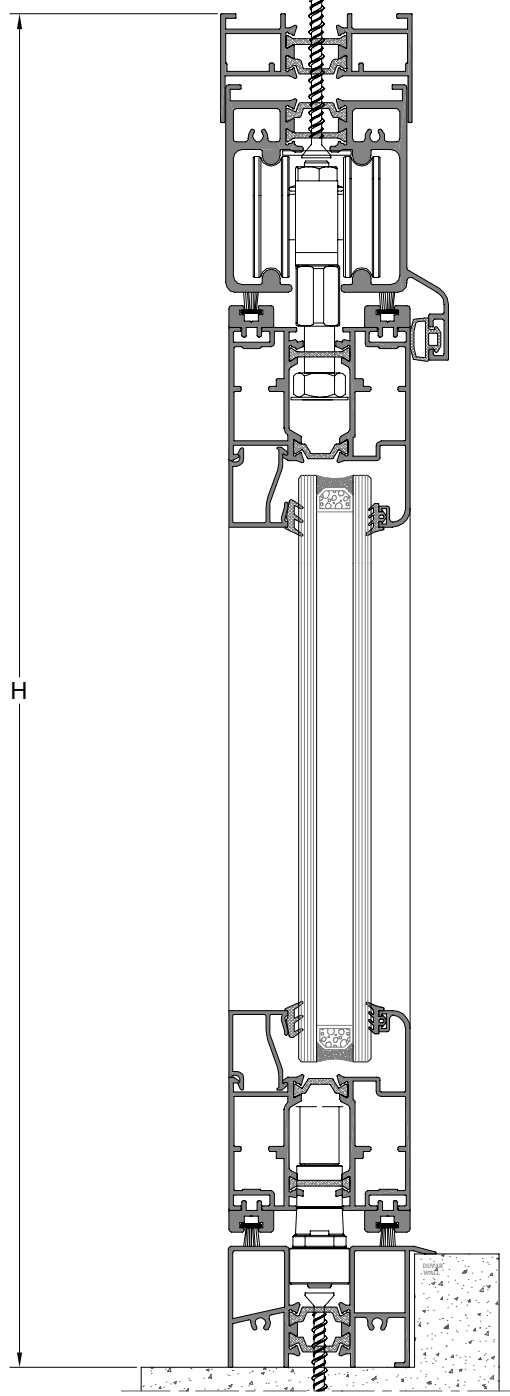

**SLIM EŞİKLİ SİSTEM KESİM ÖLÇÜSÜ**

PROFILE CUT DIMENSION FOR SLIM THRESHOLD SYSTEM

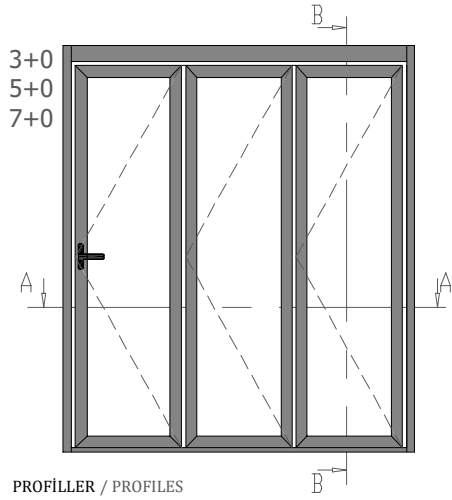

PROFİLLER / PROFILES

NOT : A= Kanat Adeti

Kod Code	Çizim Drawing	Kesim Cut	Miktar Quantity	Ölçüler Dimensions
3662-3662 Kasa Profili Frame Profile			2 Adet	H
3660-3661 Kanat Profili Sash Profile			2 x A	$L-(68+(A+1) \times 13)$ A
			2 x A	H-114
11833-11834 veya 11832-11833 Eşik Profili Threshold Profile			1	L-68
			1	L-68
3663-3664 Üst Kasa Profili Top Frame Profile			1	L-68
3668 Fırça Adaptör Profili Brush Adapter Profile			3 x A	Kanat Geniřliđi+13
			3 x A	Kanat Yüksekliđi x 1
3669 Adaptör Profili Adapter Profile			1	Kanat Yüksekliđi x 1

CAM / GLAZING

Kod Code	Çizim Drawing	Miktar Quantity	Ölçüler Dimensions
CAM GLAZING		A	GL = SL-102
			GH = SH-102

CAM ÖLÇÜLERİ EŞİT KABUL EDİLEREK FORMÜLE EDİLMİŐTİR.  
GLAZING DIMENSIONS ARE ASSUMED TO BE EQUAL.

**A-A KESİTİ**

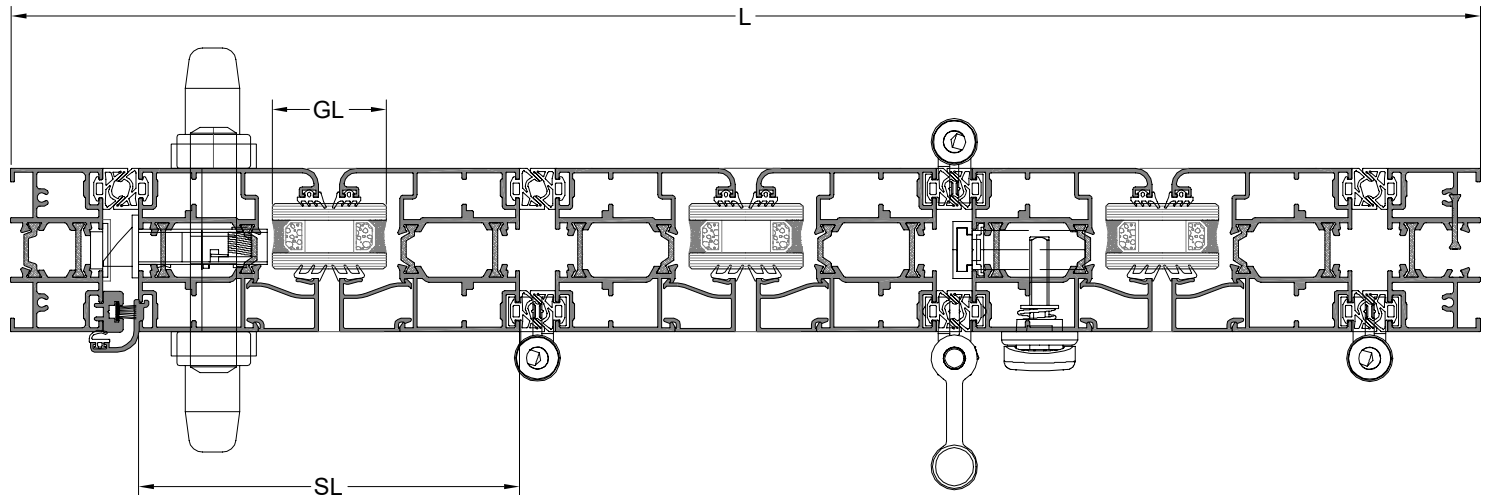

**B-B KESİTİ**

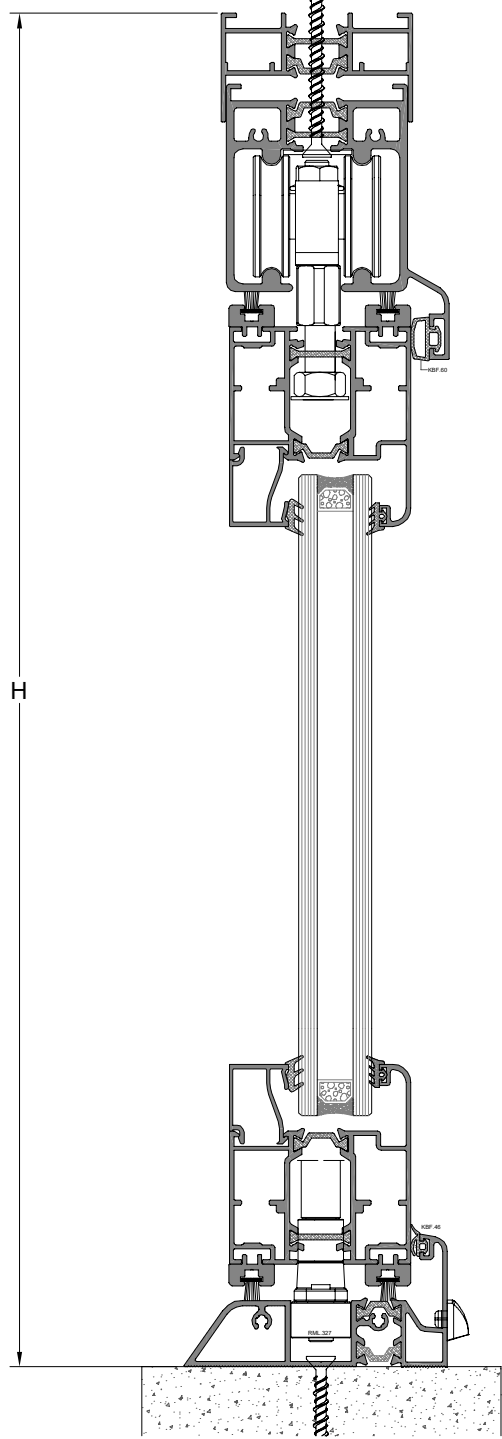

**YÜKSEK EŞİKLİ SİSTEM KESİM ÖLÇÜSÜ**

PROFILE CUT DIMENSION FOR HIGH THRESHOLD SYSTEM

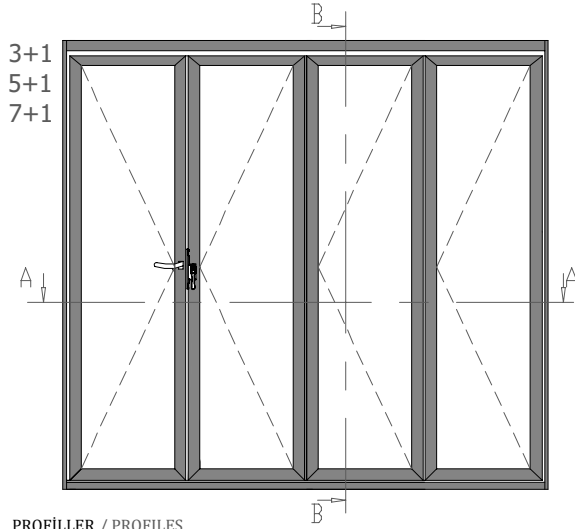

**PROFİLLER / PROFILES**

NOT : A= Kanat Adeti

Kod Code	Çizim Drawing	Kesim Cut	Miktar Quantity	Ölçüler Dimensions
3662-3662 Kasa Profili Frame Profile			3 Adet	H
3660-3661 Kanat Profili Sash Profile			2 x A	$\frac{L-(114,2+(A+1) \times 13)}{A}$
			2 x A	H-132
3666-3667 veya 3667-3667 Eşik Profili Threshold Profile			1	L-68
			1	L-68
3663-3664 Üst Kasa Profili Top Frame Profile			1	L-68
3668 Fırça Adaptör Profili Brush Adapter Profile			3 x A	Kanat Genişliği+13
			3 x A	Kanat Yüksekliği x 1
3669 Adaptör Profili Adapter Profile			1	Kanat Yüksekliği x 1

**CAM / GLAZING**

Kod Code	Çizim Drawing	Miktar Quantity	Ölçüler Dimensions
CAM GLAZING		A	GL = SL-102
			GH = SH-102

**B-B KESİTİ**

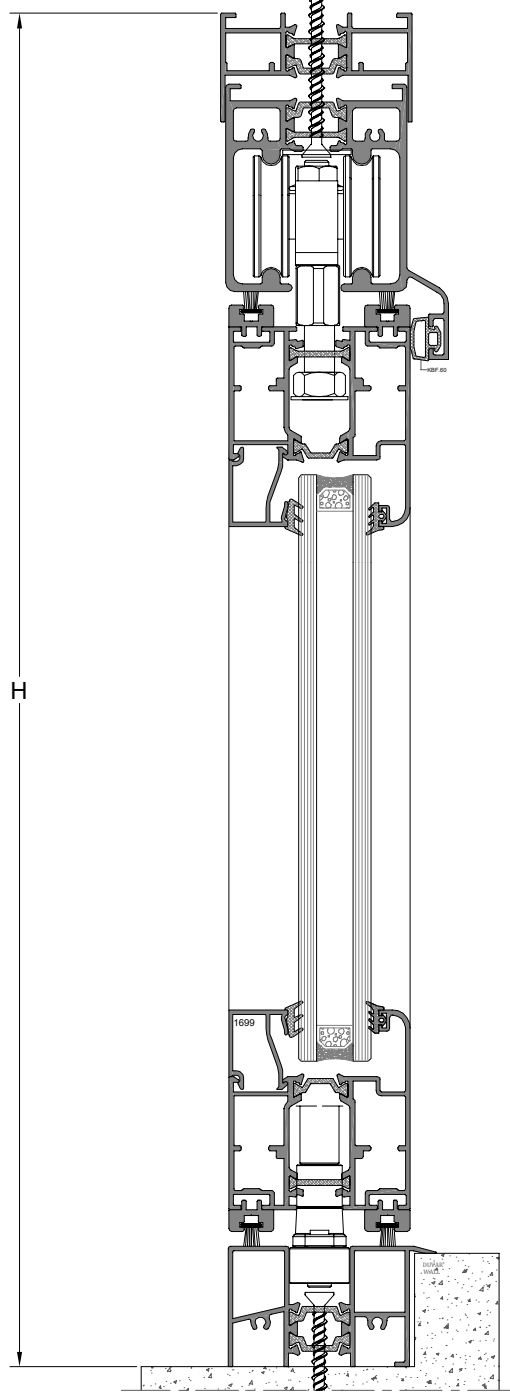

CAM ÖLÇÜLERİ EŞİT KABUL EDİLEREK FORMÜLE EDİLMİŞTİR.  
GLAZING DIMENSIONS ARE ASSUMED TO BE EQUAL.

**A-A KESİTİ**

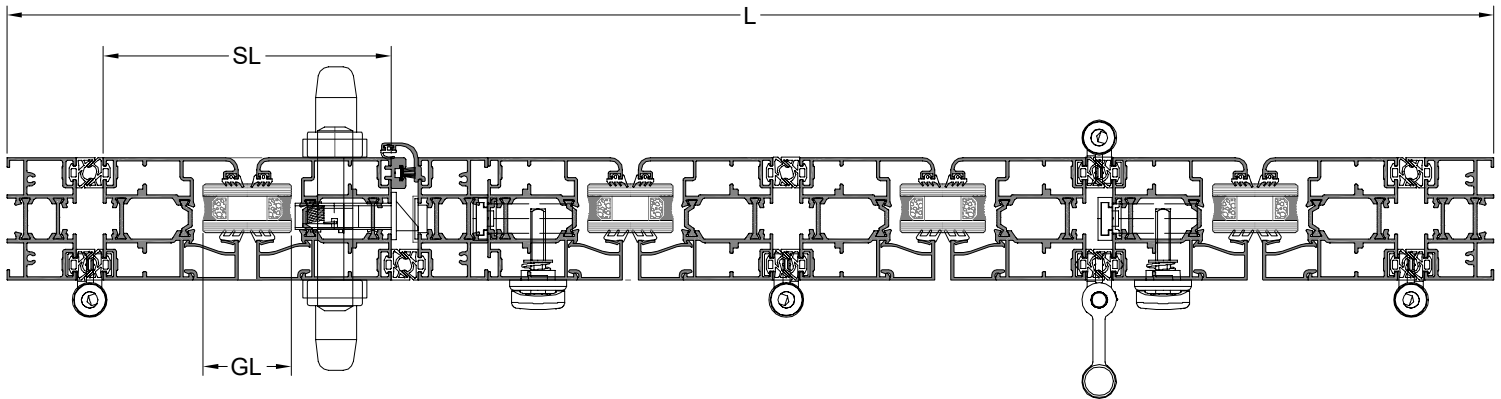

**SLIM EŞİKLİ SİSTEM KESİM ÖLÇÜSÜ**

PROFILE CUT DIMENSION FOR SLIM THRESHOLD SYSTEM

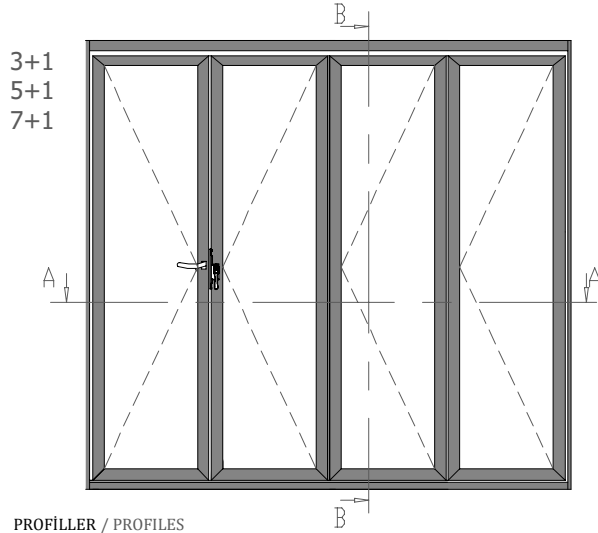

PROFİLLER / PROFILES

NOT : A= Kanat Adeti

Kod Code	Çizim Drawing	Kesim Cut	Miktar Quantity	Ölçüler Dimensions
3662-3662 Kasa Profili Frame Profile			3 Adet	H
3660-3661 Kanat Profili Sash Profile			2 x A	$L - \frac{(114,2 + (A+1) \times 13)}{A}$
			2 x A	H-114
11833-11834 veya 11832-11833 Eşik Profili Threshold Profile			1	L-68
			1	L-68
3663-3664 Üst Kasa Profili Top Frame Profile			1	L-68
3668 Fırça Adaptör Profili Brush Adapter Profile			3 x A	Kanat Genişliği+13
			3 x A	Kanat Yüksekliği x 1
3669 Adaptör Profili Adapter Profile			1	Kanat Yüksekliği x 1

CAM / GLAZING

Kod Code	Çizim Drawing	Miktar Quantity	Ölçüler Dimensions
CAM GLAZING		A	GL = SL-102
			GH = SH-102

CAM ÖLÇÜLERİ EŞİT KABUL EDİLEREK FORMÜLE EDİLMİŞTİR.  
GLAZING DIMENSIONS ARE ASSUMED TO BE EQUAL.

**A-A KESİTİ**

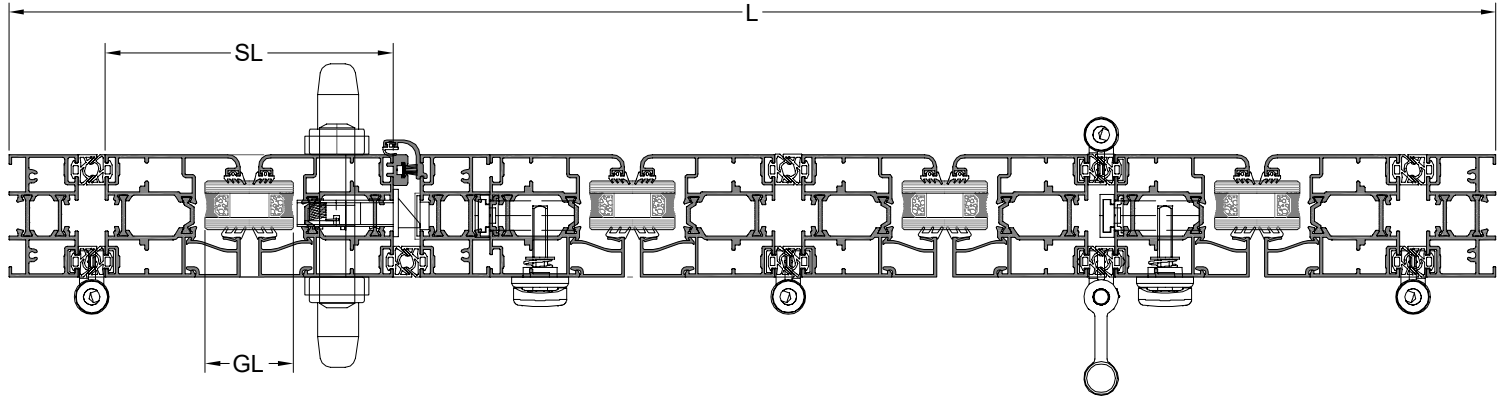

**B-B KESİTİ**

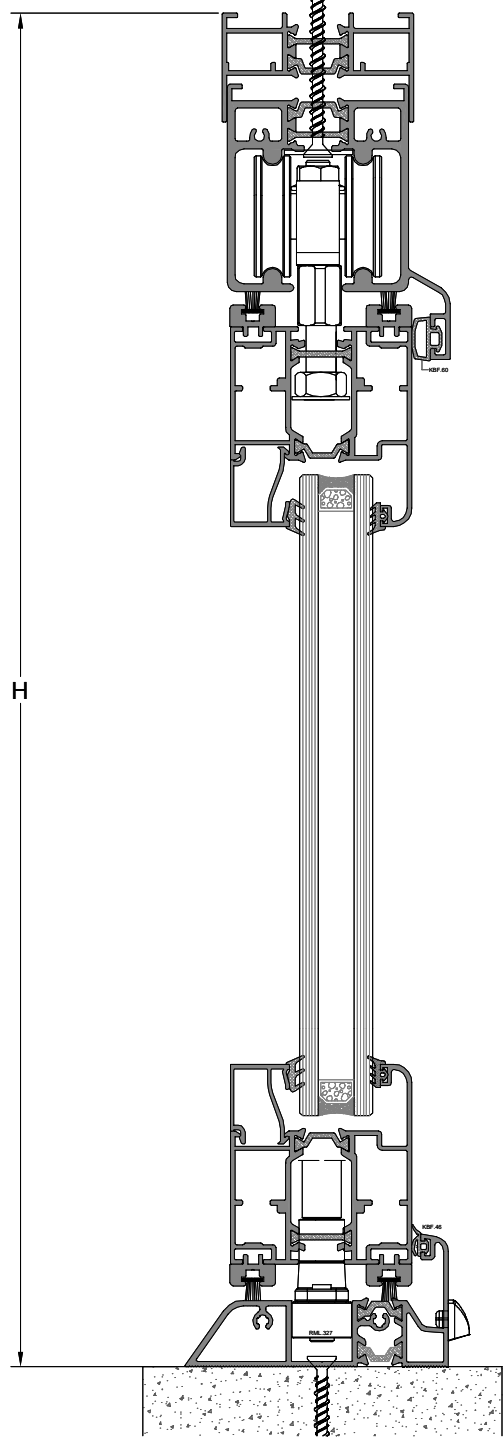

**KASA MONTAJI**  
FRAME ASSEMBLY

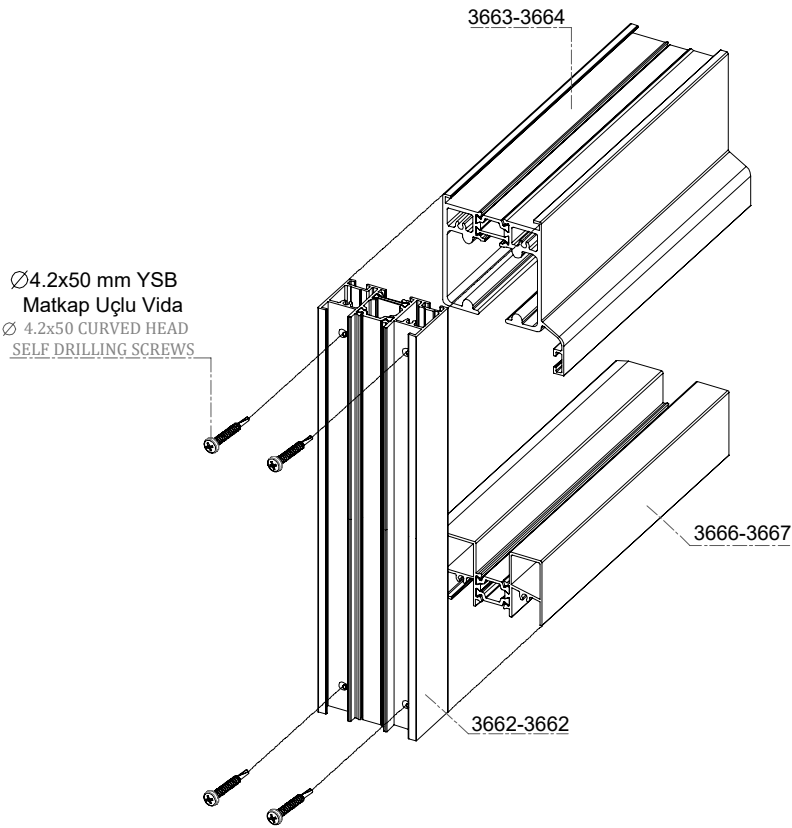
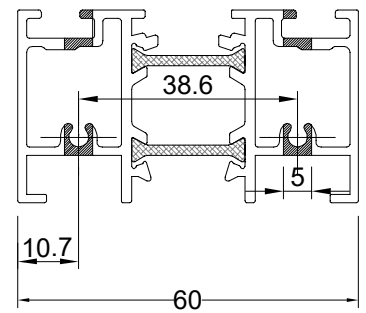
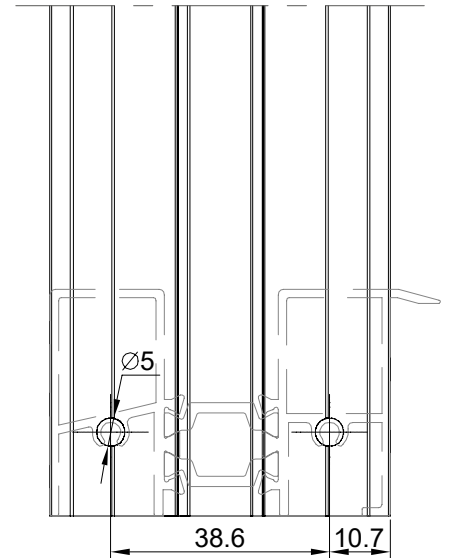
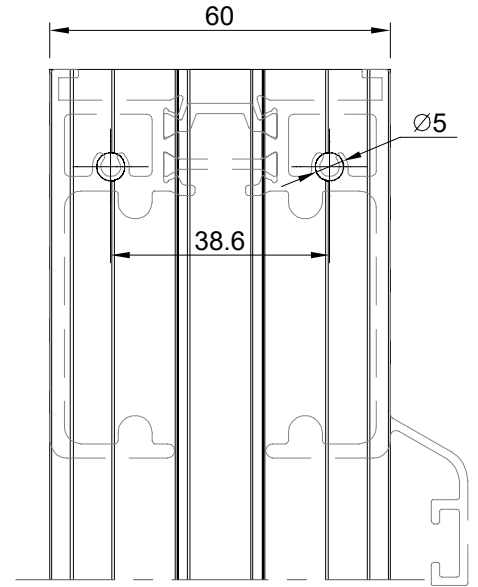
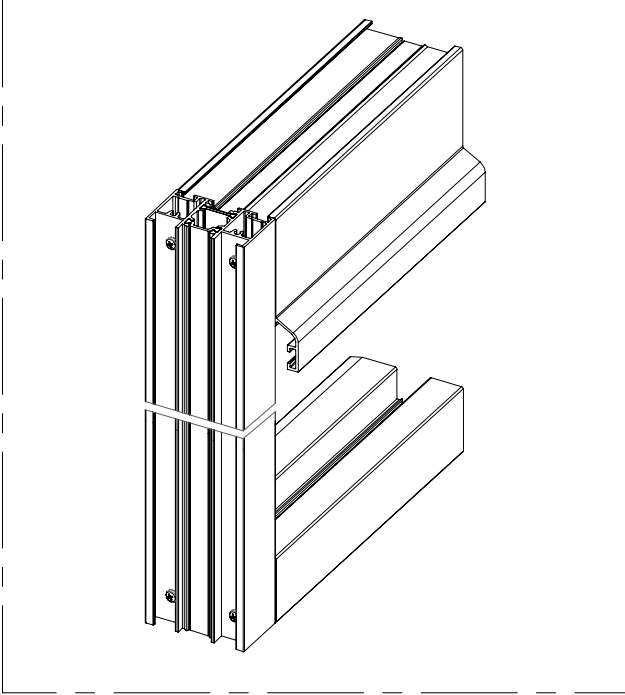

**KANAT MONTAJI**  
SASH ASSEMBLY

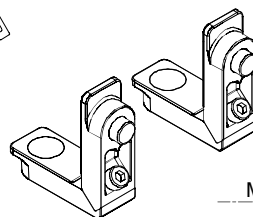
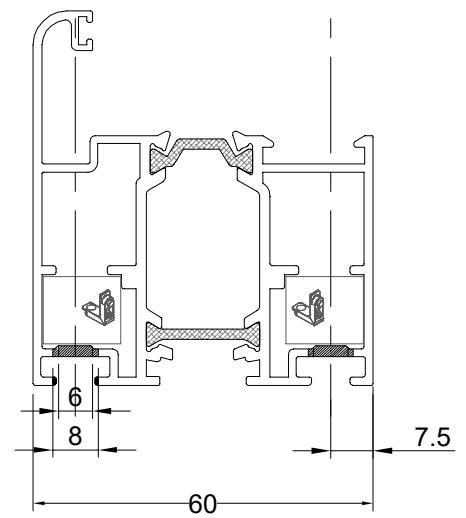
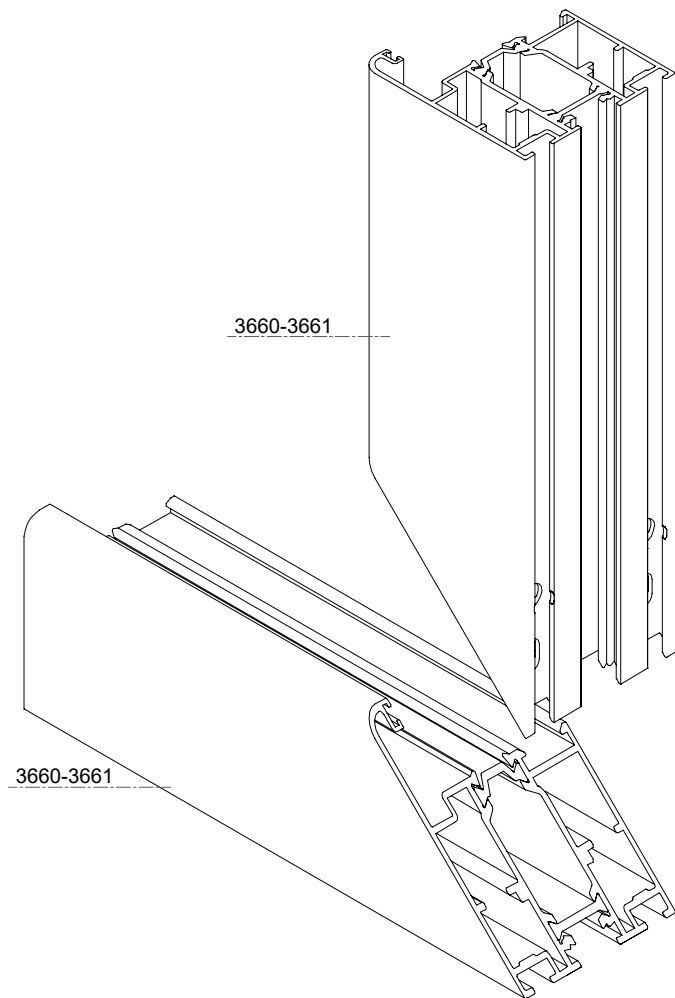
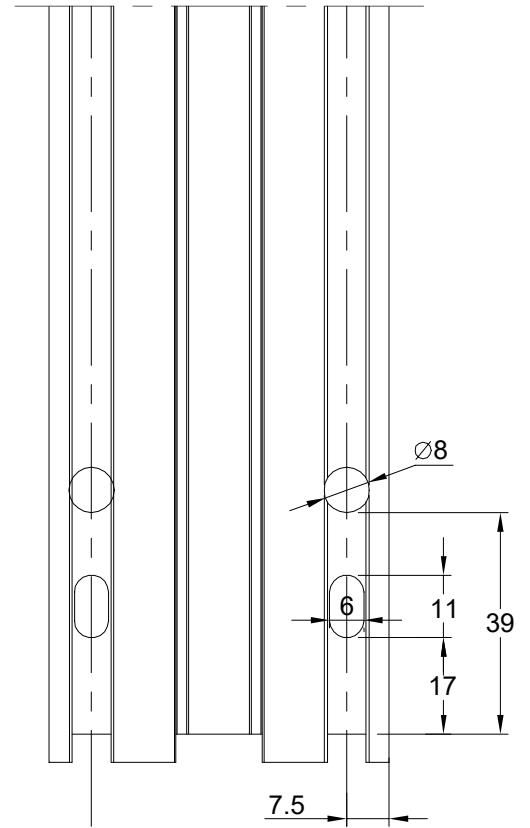
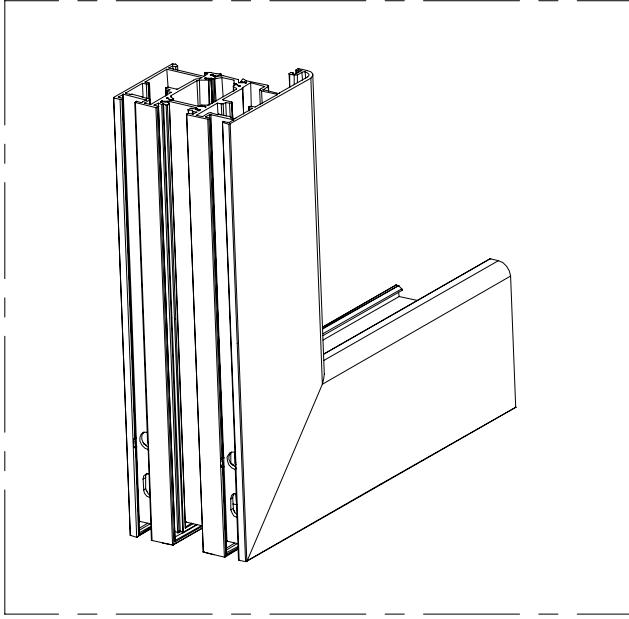



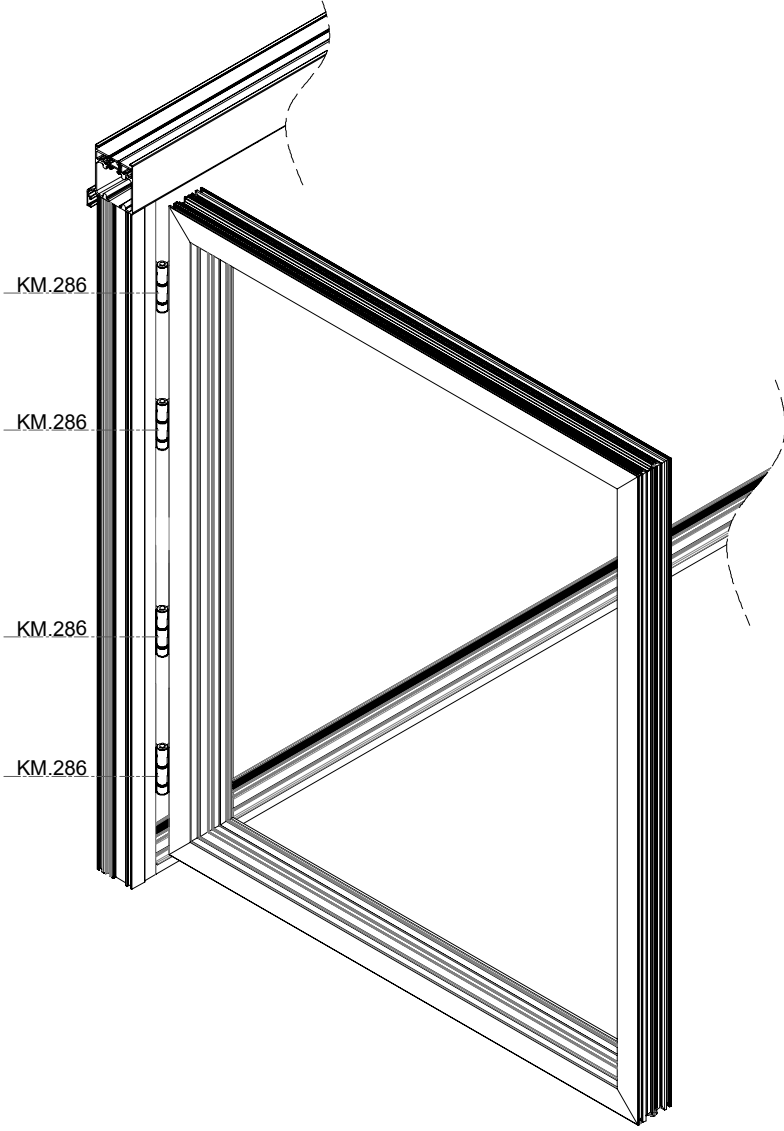

**A** MENTEŞE BAĞLANTI NOKTASI  
JOIN POINT A

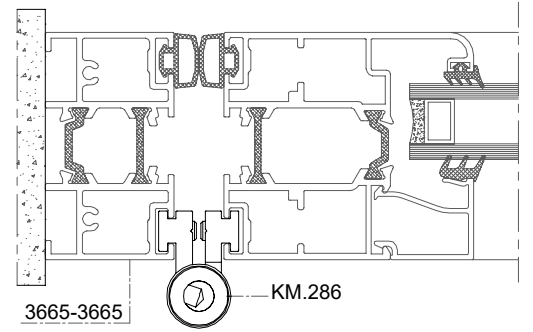
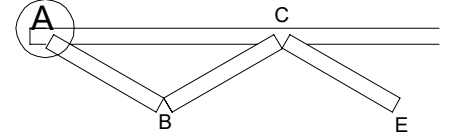

H (mm)	Menteşe Adet HINGE PCS	Menteşe AKS Mesafeleri HINGE AXLE DISTANCES (mm)			
		D1	D2	D3	D4
0-2400	3	130	650	-	130
2401-2600	4	130	650	650	130

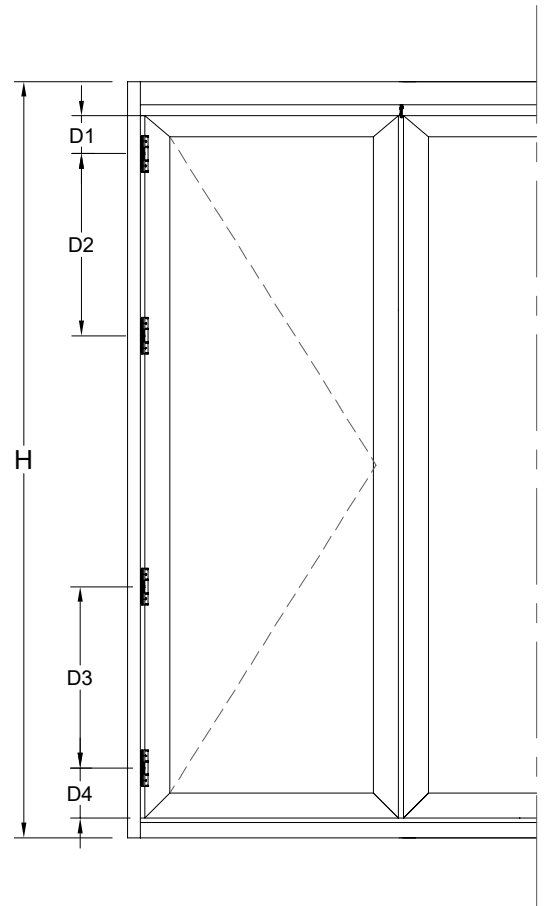





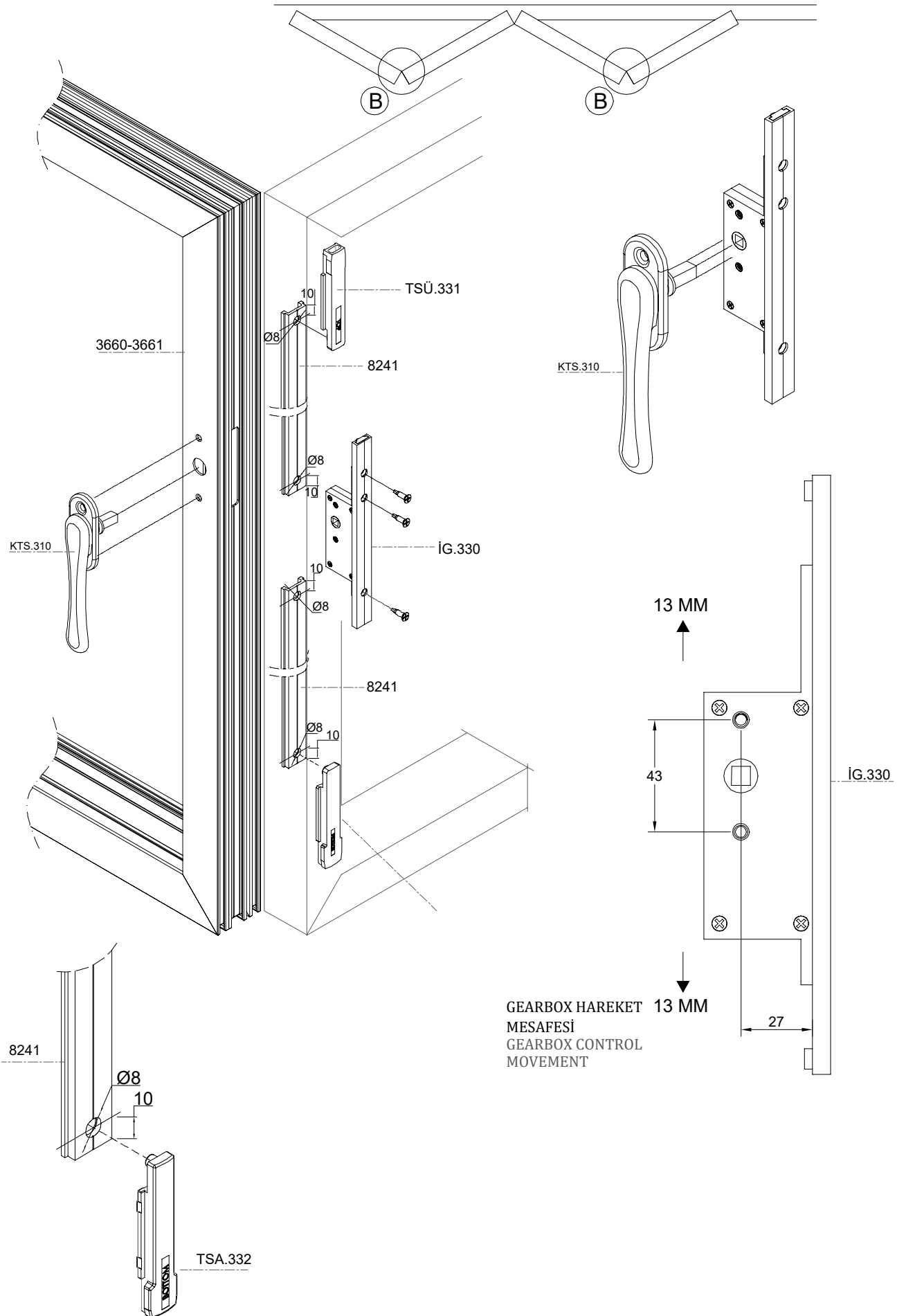

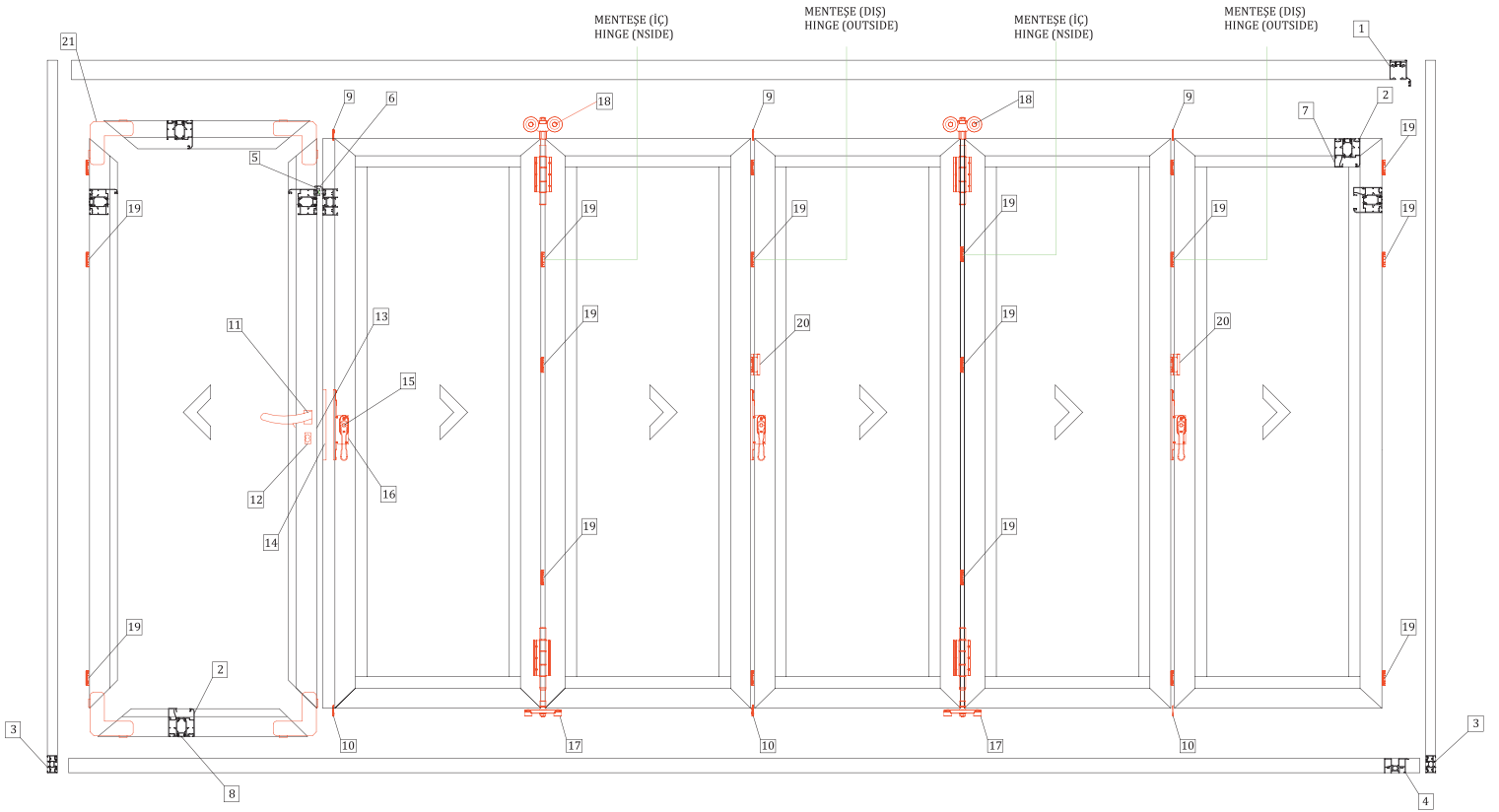
**B** GEARBOX VE KOL MONTAJ DETAYI  
ASSEMBLY DETAILS FOR GEARBOX AND HANDLE

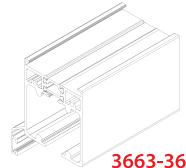
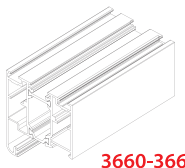
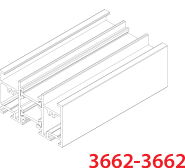
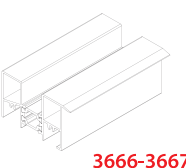
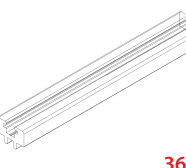
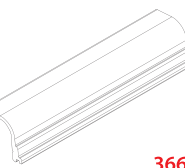
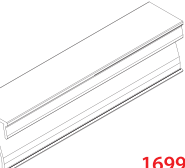

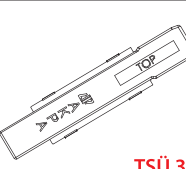
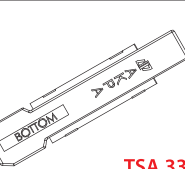
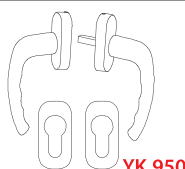
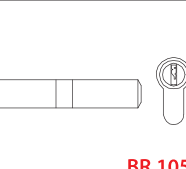
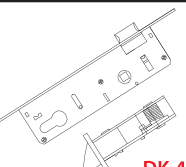
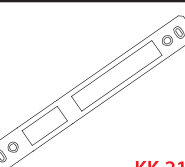

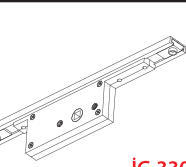
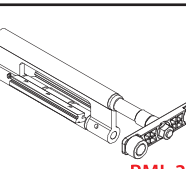
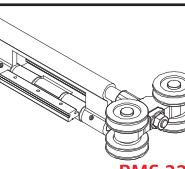
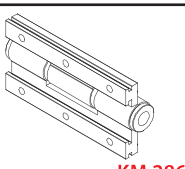
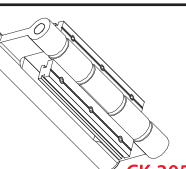
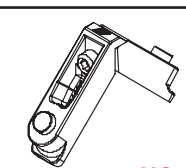
1	 3663-3664	2	 3660-3661	3	 3662-3662	4	 3666-3667
5	 3668	6	 3669	7	 1699	8	 8241
9	 TSÜ.331	10	 TSA.332	11	 YK.950	12	 BR.105
13	 DK.401	14	 KK.210	15	 KTS.310	16	 İĞ.330
17	 RML.327	18	 RMS.320	19	 KM.286	20	 CK.305
21	 MC.110						