

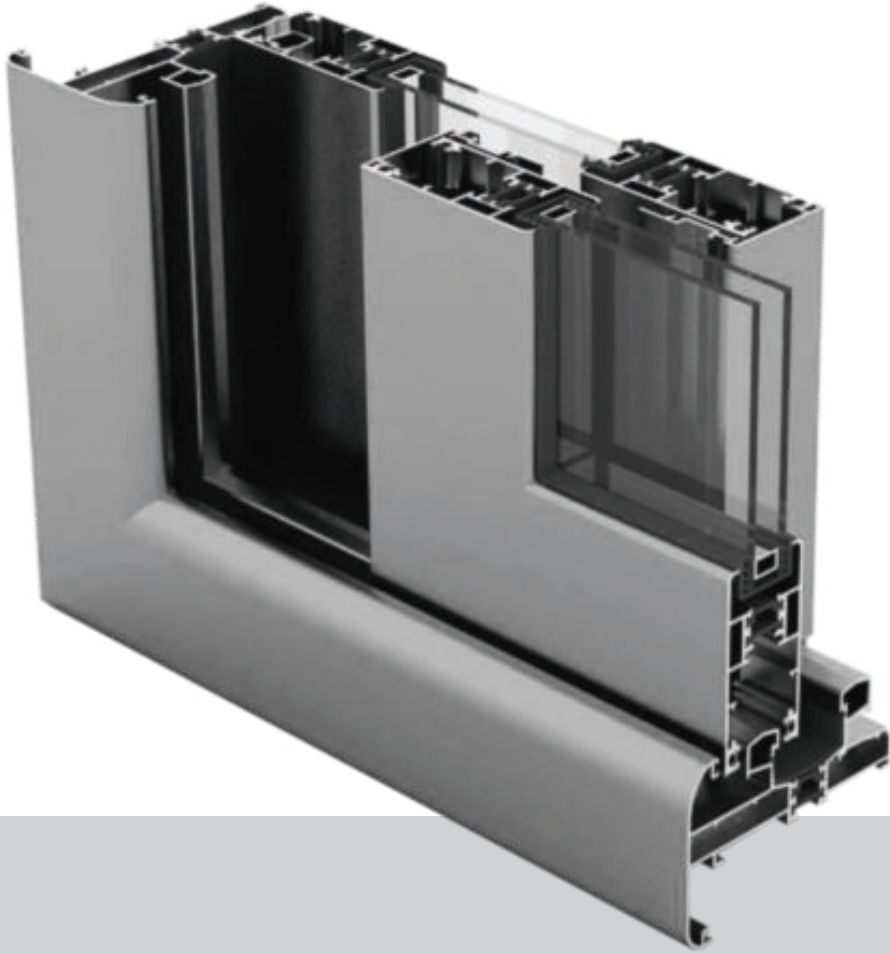

Sürme Sistem  
Sliding System

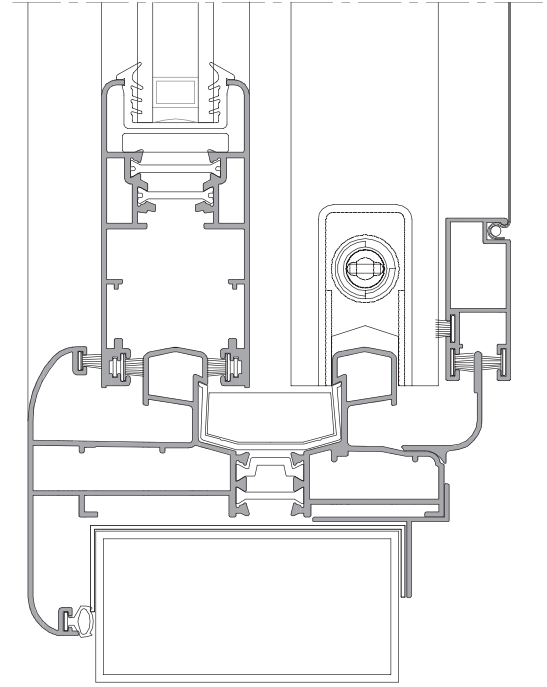

# CS35T

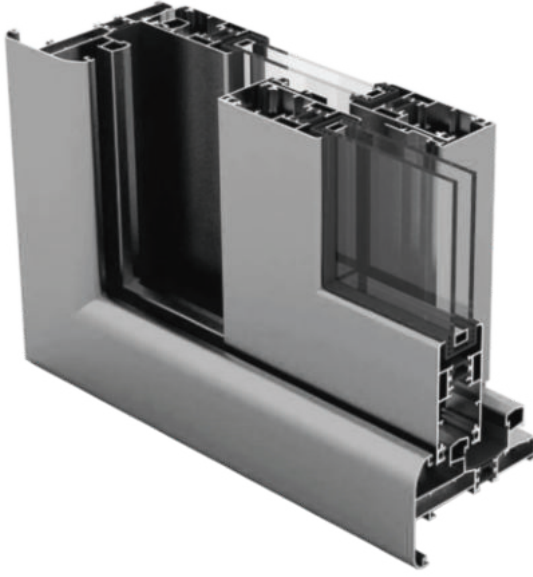

### TEKNİK ÖZELLİKLER / TECHNICAL PROPERTIES

<b>KASA DERİNLİĞİ / FRAME DEPTH</b>	<b>82 - 160 mm</b>
<b>KANAT DERİNLİĞİ / SASH DEPTH</b>	<b>39 mm</b>
<b>KENET DERİNLİĞİ / INTERLOCKING DEPTH</b>	<b>89 mm</b>
<b>PROFİL ET KALINLIĞI / PROFILE WALL THICKNESS</b>	<b>1,3 - 1,5 mm</b>
<b>ISI BARIYERİ / THERMAL BREAK</b>	<b>18 - 24 mm</b>
<b>CAM KALINLIĞI / GLAZING THICKNESS</b>	<b>20 mm</b>
<b>MİN. KANAT ÖLÇÜLERİ / MIN. SASH DIMENSIONS</b>	<b>800 x 1900 mm</b>
<b>MAKS. KANAT ÖLÇÜLERİ / MAX. SASH DIMENSIONS</b>	<b>1600 x 2800 mm</b>
<b>MAKS. KANAT AĞIRLIĞI / MAX. SASH WEIGHT</b>	<b>160 kg</b>
<b>MİN. TERMAL ISI YALITIMI / MIN. THERMAL INSULATION</b>	<b><math>U_f : 5,49 - 6,24 W / ( m^2 \cdot K )</math></b>

### UYGULAMA SEÇENEKLERİ / APPLICATION OPTIONS

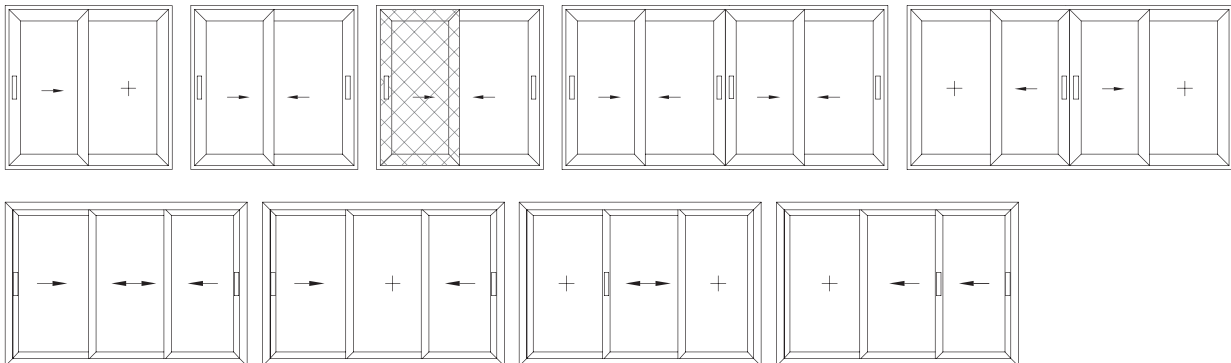

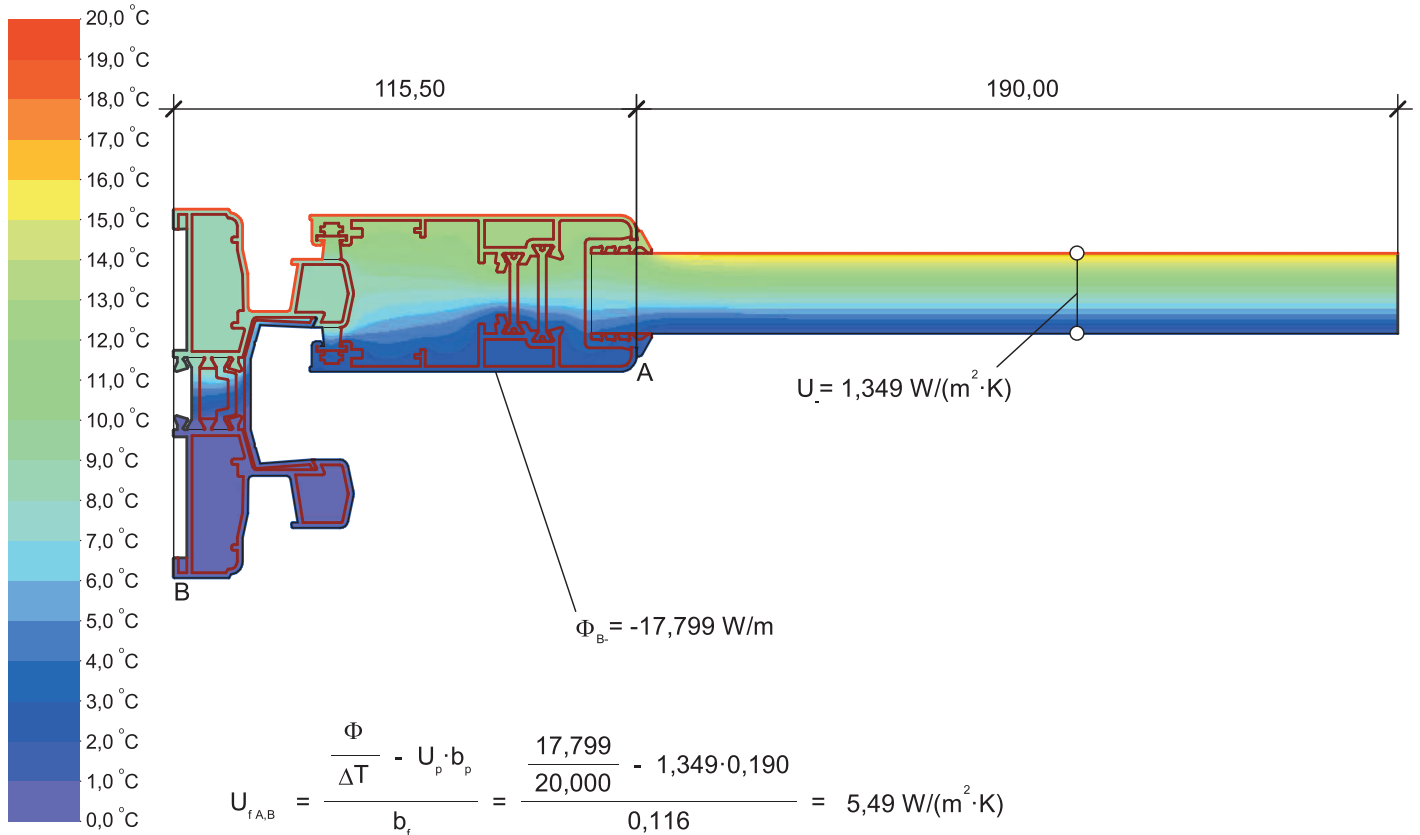

Material	$\lambda$ [W/(m·K)]	$\epsilon$	Boundary Condition	$q$ [W/m <sup>2</sup> ]	$\theta_f$ [°C]	$R$ [(m <sup>2</sup> ·K)/W]	$\epsilon$
Aluminium (Si Alloys)	160,000	0,900	Epsilon 0.9				0,900
EPDM (ethylene propylene diene monomer)	0,250	0,900	Exterior, frame	0,000	0,040		
PVC (polyvinylchloride), rigid	0,170	0,900	Interior, normal, horizontal	20,000	0,130		
Panel	0,035	0,900	Symmetry/Model section	0,000			
Polyamid 6.6 with 25% glass fibre	0,300	0,900					
Slightly ventilated air cavity	anisotropic						
Unventilated air cavity	anisotropic						

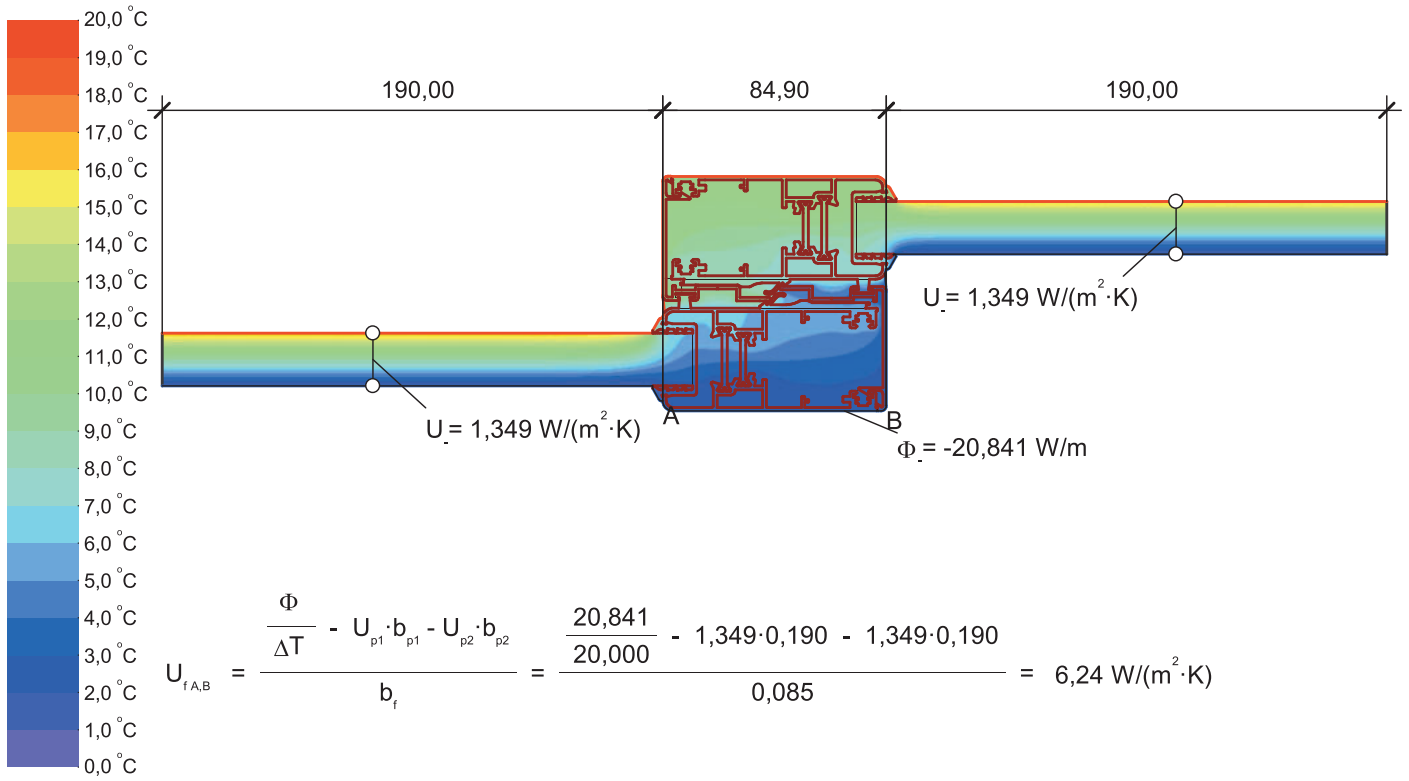

Material	$\lambda$ [W/(m·K)]	$\epsilon$	Boundary Condition	$q$ [W/m <sup>2</sup> ]	$\theta_f$ [°C]	$R$ [(m <sup>2</sup> ·K)/W]	$\epsilon$
Aluminium (Si Alloys)	160,000	0,900	Epsilon 0.9				0,900
EPDM (ethylene propylene diene monomer)	0,250	0,900	Exterior, frame	0,000	0,040		
PVC (polyvinylchloride), rigid	0,170	0,900	Interior, normal, horizontal	20,000	0,130		
Panel	0,035	0,900	Symmetry/Model section	0,000			
Polyamid 6.6 with 25% glass fibre	0,300	0,900					
Slightly ventilated air cavity	anisotropic						
Unventilated air cavity	anisotropic						

# RÜZGAR YÜKÜNE GÖRE KULLANIM LİMİTLERİ GRAFIĞI

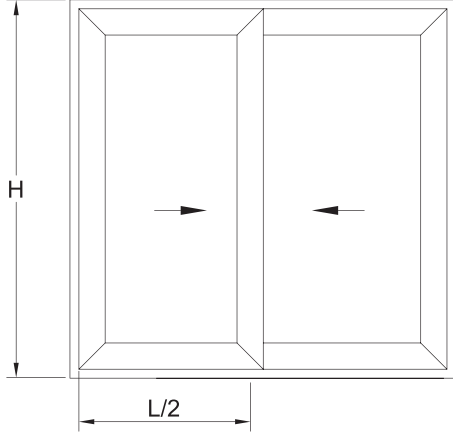

Max. Sehim :  $L / 300$

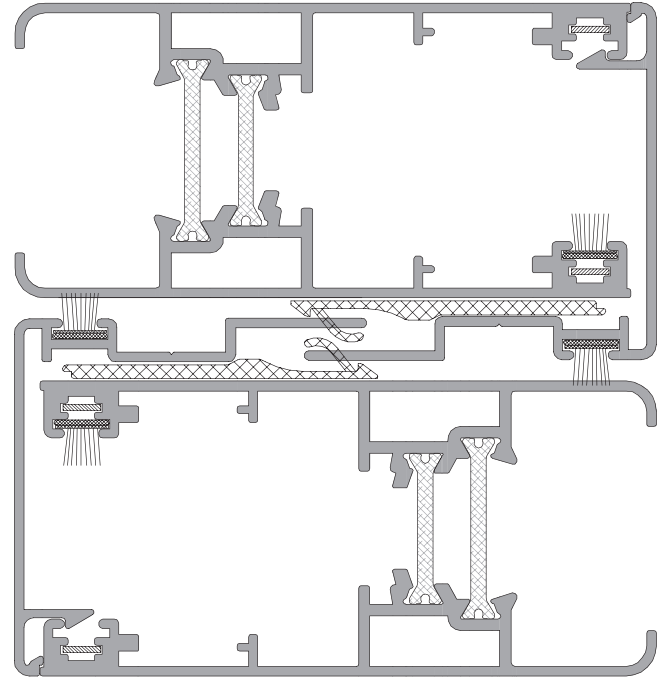
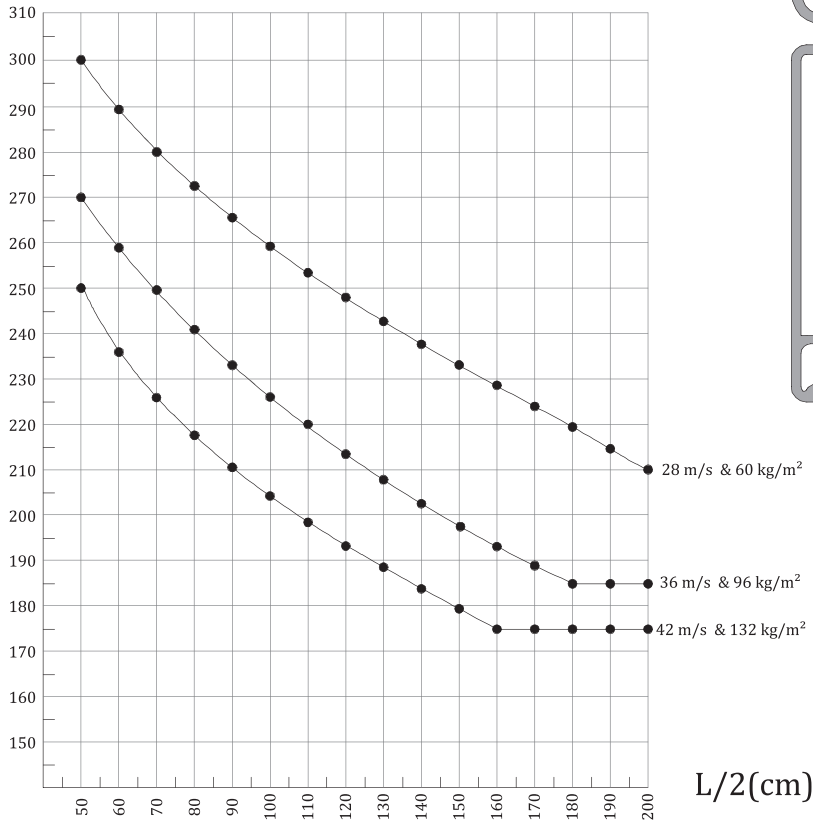

$J_x : 31,88 \text{ cm}^4$







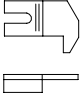
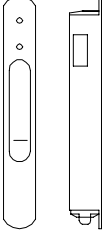

L/2(cm)

PROFİL KESİTİ PROFILE SECTION	PROFİL KODU PROFILE CODE	PROFİL ADI PROFILE NAME	Jx cm <sup>4</sup>	Jy cm <sup>4</sup>	AĞIRLIK (kg/m) WEIGHT
	3647-3648	İKİ RAYLI KASA PROFİLİ DOUBLE RAIL FRAME PROFILE	86,17 cm <sup>4</sup>	21,45 cm <sup>4</sup>	2,051 kg/mt
	5591-5592	İKİ RAYLI KASA PROFİLİ DOUBLE RAIL FRAME PROFILE	46,77 cm <sup>4</sup>	16,71 cm <sup>4</sup>	1,767 kg/mt
	3648-3648	İKİ RAYLI KASA PROFİLİ DOUBLE RAIL FRAME PROFILE	38,74 cm <sup>4</sup>	9,67 cm <sup>4</sup>	1,595 kg/mt
	3647-3659-3648	ÜÇ RAYLI KASA PROFİLİ TRIPLE RAIL FRAME PROFILE	245,29 cm <sup>4</sup>	25,67 cm <sup>4</sup>	2,950kg/mt
	5591-3659-3648	ÜÇ RAYLI KASA PROFİLİ TRIPLE RAIL FRAME PROFILE	192,60cm <sup>4</sup>	21,74 cm <sup>4</sup>	2,790kg/mt
	3650-3650	KANAT PROFİLİ SASH PROFILE	25,18 cm <sup>4</sup>	12,03 cm <sup>4</sup>	1,412 kg/mt
	1243	SİNEKLİK PROFİLİ SCREENING PROFILE	-	-	0,434 kg/mt
	12339	SİNEKLİK PROFİLİ SCREENING PROFILE	-	-	0,703 kg/mt
	3594	TAKVİYE PROFİLİ REINFORCE PROFILE	-	-	0,456 kg/m
	3595	TAKVİYE KAPAK PROFİLİ REINFORCE COVER PROFILE	-	-	0,101 kg/m
	2707	SİNEKLİK RAY PROFİLİ SCREENING RAIL PROFILE	-	-	0,190 kg/mt
	3651	KENET PROFİLİ INTERLOCKING PROFILE	-	-	0,415 kg/mt
	5598	DAMLALIK PROFİLİ DROPPER PROFILE	-	-	0,302 kg/mt
	3649	ADAPTÖR PROFİLİ ADAPTER PROFILE	-	-	0,548 kg/mt
	1139	T BAĞLANTI PROFİLİ T CONNECTION PROFILE	-	-	0,236 kg/mt
	1035	T BAĞLANTI PROFİLİ T CONNECTION PROFILE	-	-	0,240 kg/mt
	1121	T BAĞLANTI PROFİLİ T CONNECTION PROFILE	-	-	0,233 kg/mt
	1123	T BAĞLANTI PROFİLİ T CONNECTION PROFILE	-	-	0,355 kg/mt
	3917	T BAĞLANTI PROFİLİ T CONNECTION PROFILE	-	-	0,162 kg/mt
	3818	T BAĞLANTI PROFİLİ T CONNECTION PROFILE	-	-	0,210 kg/mt
	3832	T BAĞLANTI PROFİLİ T CONNECTION PROFILE	-	-	0,175 kg/mt
	553	PERVAZ PROFİLİ SILL PROFILE	-	-	0 ,656 kg/mt
	3646	PERVAZ PROFİLİ SILL PROFILE	-	-	0 ,302 kg/mt
	598	KÖŞE TAKOZ PROFİLİ CORNER WEDGE PROFILE	-	-	1,760 kg/mt
	6568	KÖŞE TAKOZ PROFİLİ CORNER WEDGE PROFILE	-	-	2,128 kg/mt

AKSESUAR ACCESSORY	STOK KODU REFERENCE CODE	AKSESUAR ADI DESCRIPTION	AKSESUAR KODU PRODUCT CODE	PAKET PACK
	03 012022	ÇİFT CAM U FİTİL DOUBLE GLASS U GASKET	CS35T-UCF.022	60 mt / paket 10kg
	03 010436	KASA FİTİLİ FRAME GASKET	CS35T-KBF.36	350 mt / paket 10 kg
	03 080100	BİNİ FİTİLİ OVERLAPPING GASKET	CS35T-MO.60	100 mt / paket
	01 050290	KASA OLUK PLASTİĞİ FRAME GUTTER PART	CS35T-KP.290	1 boy / 6 mt
	01 050297	KENET PLASTİK INTERLOCKING PART	CS35T-KL.297	1 boy / 6 mt
	03 050710	FIRÇA FİTİL WEATHER STRIP	CS35T-FÇ.710	300 mt / paket
	03 050706	FIRÇA FİTİL WEATHER STRIP	CS35T-FÇ.706	350 mt / paket
	03 050705	FIRÇA FİTİL WEATHER STRIP	CS35T-FÇ.705	550 mt / paket
	01 130318	KÖŞE GÖNYE CORNER BRACKET	CS35T-KG.318	1 pk / 1000 ad
	01 130314	KÖŞE GÖNYE CORNER BRACKET	CS35T-KG.314	1 pk / 250 ad
	01 050253	KENET KAPAK INTERLOCKING COVER	CS35T-YK.253	1 pk / 100 ad
 10,6 mm x 19 mm	01 130306	ALYAN KÖŞE BAĞLANTI ALLEN CORNER JOINT	CS35T-MC.306	1 pk / 250 ad
	01050251	KANAT KÖŞE BAĞLANTI SASH CORNER JOINT	CS35T-KT.251	1 pk / 100 ad
	01 050298	ALT HAVA KESİCİ BOTTOM AIR BLOCKER	CS35T-AHK.298	1 pk / 100 ad
	01 071030	ÜST HAVA KESİCİ TOP AIR BLOCKER	CS35T-ÜHK.030	1 pk / 1 ad
	01 050060	STOPER STOPPER	CS35T-SP.060	1 pk / 100 ad
	01 050200	KİLİT KARŞILIK (NATUREL) STRIKER FOR SLIDING LOCK (NATURAL)	CS35T-KT.200	1 pk / 100ad
	01 050201	KİLİT KARŞILIK (BEYAZ) STRIKER FOR SLIDING LOCK (WHITE)	CS35T-KT.201	1 pk / 100ad
	01 050202	KİLİT KARŞILIK (SİYAH) STRIKER FOR SLIDING LOCK (BLACK)	CS35T-KT.202	1 pk / 100ad
	01 050050	ÇİFTLİ RULMAN DOUBLE ROLLER	CS35T-ÇR.050	1 pk / 100 ad

AKSESUAR ACCESSORY	STOK KODU REFERENCE CODE	AKSESUAR ADI DESCRIPTION	AKSESUAR KODU PRODUCT CODE	PAKET PACK
	01 050750	FORZA YAYLI HAVUZ KOL (SİYAH) FORZA RECESSED HANDLE AUTOMATIC (BLACK)	CS35T-FHK.750	1 pk / 40 ad
	01 050751	FORZA YAYLI HAVUZ KOL (BEYAZ) FORZA RECESSED HANDLE AUTOMATIC (WHITE)	CS35T-FHK.751	1 pk / 40 ad
	01 050752	FORZA YAYLI HAVUZ KOL (NATUREL) FORZA RECESSED HANDLE AUTOMATIC (NATURAL)	CS35T-FHK.752	1 pk / 40 ad
	01 050753	FORZA YAYLI HAVUZ KOL (ANTRASİT) FORZA RECESSED HANDLE AUTOMATIC (ANTHRACITE)	CS35T-FHK.753	1 pk / 40 ad
	01 050760	FORZA MANUEL HAVUZ KOL (SİYAH) FORZA RECESSED HANDLE MANUEL (BLACK)	CS35T-FHK.760	1 pk / 40 ad
	01 050761	FORZA MANUEL HAVUZ KOL (BEYAZ) FORZA RECESSED HANDLE MANUEL (WHITE)	CS35T-FHK.761	1 pk / 40 ad
	01 050762	FORZA MANUEL HAVUZ KOL (NATUREL) FORZA RECESSED HANDLE MANUEL (NATURAL)	CS35T-FHK.762	1 pk / 40 ad
	01 050763	FORZA MANUEL HAVUZ KOL (ANTRASİT) FORZA RECESSED HANDLE MANUEL (ANTHRACITE)	CS35T-FHK.763	1 pk / 40 ad
	01 050770	FORZA ANAHTARLI HAVUZ KOL (SİYAH)	CS35T-FHK.770	1 pk / 40 ad
	01 050771	FORZA ANAHTARLI HAVUZ KOL (BEYAZ) FORZA RECESSED HANDLE LOCK WITH KEY (WHITE)	CS35T-FHK.771	1 pk / 40 ad
	01 050772	FORZA ANAHTARLI HAVUZ KOL (NATUREL) FORZA RECESSED HANDLE LOCK WITH KEY (NATURAL)	CS35T-FHK.772	1 pk / 40 ad
	01 050773	FORZA ANAHTARLI HAVUZ KOL (ANTRASİT) FORZA RECESSED HANDLE LOCK WITH KEY(ANTHRACITE)	CS35T-FHK.773	1 pk / 40 ad
	01 050790	FORZA PASİF HAVUZ KOL (SİYAH) FORZA RECESSED FINGER PULL HANDLE (BLACK)	HS55T-FHK.790	1 pk / 40 ad
	01 050791	FORZA PASİF HAVUZ KOL (BEYAZ) FORZA RECESSED FINGER PULL HANDLE (WHITE)	HS55T-FHK.791	1 pk / 40 ad
	01 050792	FORZA PASİF HAVUZ KOL (NATUREL) FORZA RECESSED FINGER PULL HANDLE (NATURAL)	HS55T-FHK.792	1 pk / 40 ad
	01 050793	FORZA PASİF HAVUZ KOL (ANTRASİT) FORZA RECESSED FINGER PULL HANDLE (NATURAL)	HS55T-FHK.793	1 pk / 40 ad
	01 050780	FORZA KİLİT DİLİ (ZAMAK) FORZA HOOK (ZAMAK)	CS35T-FKD.780	1 pk / 1 ad
	01 050781	FORZA KİLİT DİLİ (ZAMAK) FORZA HOOK (ZAMAK)  Forza yaylı ve manuel havuz kol ile kullanılmaktadır.	CS35T-FKD.781	1 pk / 40 ad
	01 050782	FORZA KİLİT KARŞILIĞI (ZAMAK) FORZA STRIKER (ZAMAK)	CS35T-FKK.782	1 pk / 1 ad

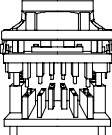

AKSESUAR ACCESSORY	STOK KODU REFERENCE CODE	AKSESUAR ADI DESCRIPTION	AKSESUAR KODU PRODUCT CODE	PAKET PACK
	01 050150	SÜRME HAVUZ KOL DİLİ SAĞ SLIDING SUNKEN HANDLE (RIGHT)	CS35-HKD.150	1 pk / 100 ad
	01 050151	SÜRME HAVUZ KOL DİLİ SOL SLIDING SUNKEN HANDLE (LEFT)	CS35T-HKD.151	1 pk / 100 ad
	01 050100	SÜRME HAVUZ KOL (NATUREL) SLIDING SUNKEN HANDLE (NATURAL)	CS35T-HK.100	1 pk / 100 ad
	01 050101	SÜRME HAVUZ KOL (BRONZ) SLIDING SUNKEN HANDLE (BRONZE)	CS35T-HK.101	1 pk / 100 ad
	01 050102	SÜRME HAVUZ KOL (BEYAZ) SLIDING SUNKEN HANDLE (WHITE)	CS35-HK.102	1 pk / 100 ad
	01 050103	SÜRME HAVUZ KOL (SİYAH) SLIDING SUNKEN HANDLE (BLACK)	CS35T-HK.103	1 pk / 100 ad
	06 140210	CAM TAKOZU(5X28X80 mm) GLAZING WEDGE 5mm	CS35T-CT.210	1 pk /1000 ad
	04105070	SİNEKLİK KÖŞE TAKOZ SCREENING CORNER WEDGE	CS35T-ST.70	1 pk / 100 ad
	04105060	SİNEKLİK RULMAN SCREENING ROLLER	CS35T-SR.60	1 pk / 100 ad
	04 100120	SİNEKLİK KÖŞE BAĞLANTI SCREENING CORNER CONNECTION	CS35T-SC.150	1 pk / 500 ad
	04 100121	SİNEKLİK RULMAN SCREENING ROLLER	CS35T-PR.140	1 pk / 4 ad
	04 060080 - 80cm	SİNEKLİK TÜLÜ SCREENING NET	CS35T-STF.80	24 m <sup>2</sup> / paket
	04 060100 - 100cm		CS35T-STF.100	30 m <sup>2</sup> / paket
	04 060120 - 120cm		CS35T-STF.120	36 m <sup>2</sup> / paket
	04 060140 - 140cm		CS35T-STF.140	44 m <sup>2</sup> / paket
	04 060160 - 160cm		CS35T-STF.160	48 m <sup>2</sup> / paket
	03 020114	SİNEKLİK FİTİLİ SCREENING GASKET	CS35T-SF.114	1 pk / 100 m
	03 020115		CS35T-SF.115	
	03 020116		CS35T-SF.116	
	02 020253	PANÇ MAKİNESİ (CS34-CS35T) PUNCH MACHINE	CS35T-PM.253	1pk / 1 Adet

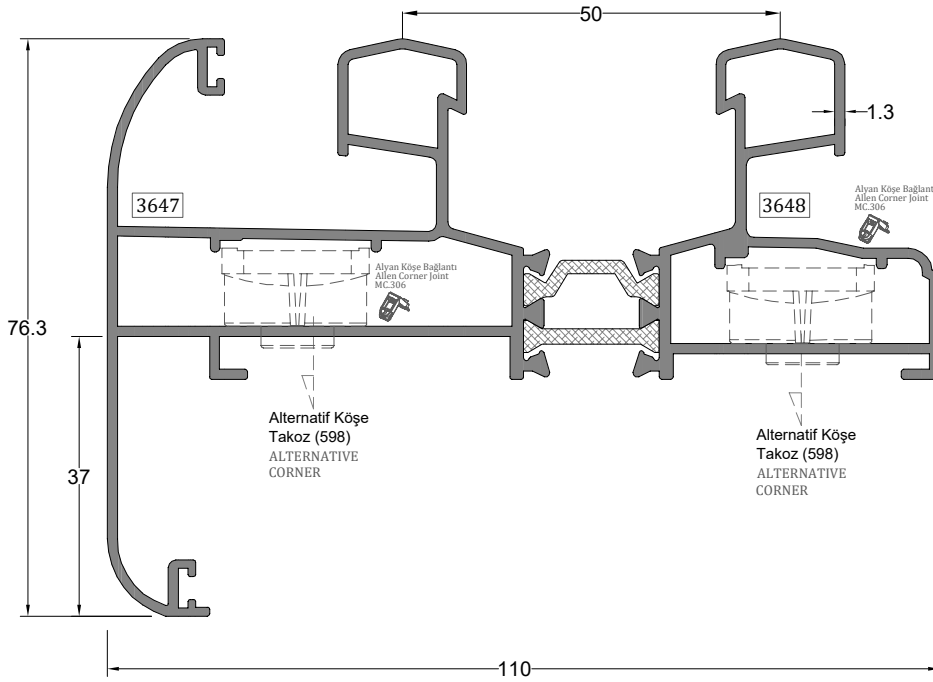

İki Raylı Kasa Profili DOUBLE RAIL FRAME PROFILE	Profil Kodu Profile Code	(kg/mt) Weight	Jx cm <sup>4</sup>	Jy cm <sup>4</sup>
	3647-3648	2,051	86,17	21,45

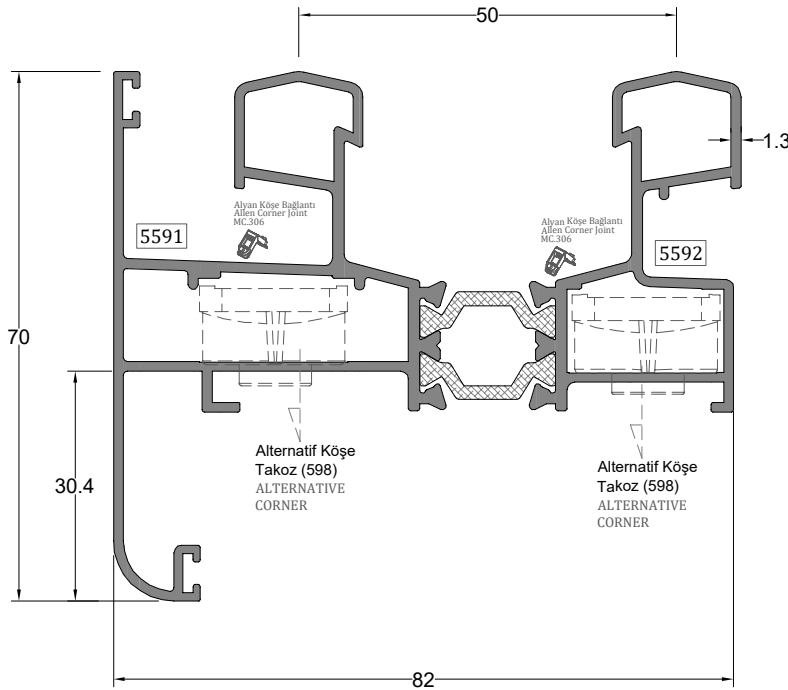

İki Raylı Kasa Profili DOUBLE RAIL FRAME PROFILE	Profil Kodu Profile Code	(kg/mt) Weight	Jx cm <sup>4</sup>	Jy cm <sup>4</sup>
	5591-5592	1,767	46,77	16,71

\*\* Her profil için minimum sipariş 300 kg'dır.  
\*\* Minimum order quantity is 300 kg per profile.

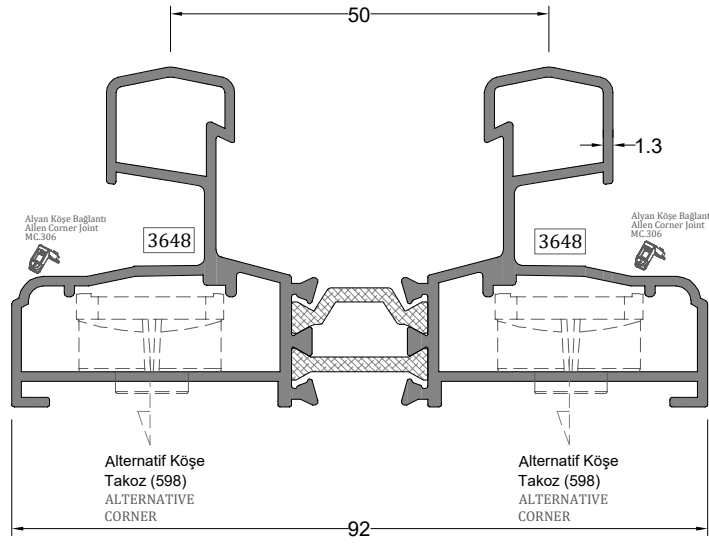

İki Raylı Kasa Profili	Profil Kodu	(kg/mt)	Jx cm <sup>4</sup>	Jy cm <sup>4</sup>
DOUBLE RAIL FRAME PROFILE	Profile Code	Weight		
	3648-3648	1,595	38,74	9,67

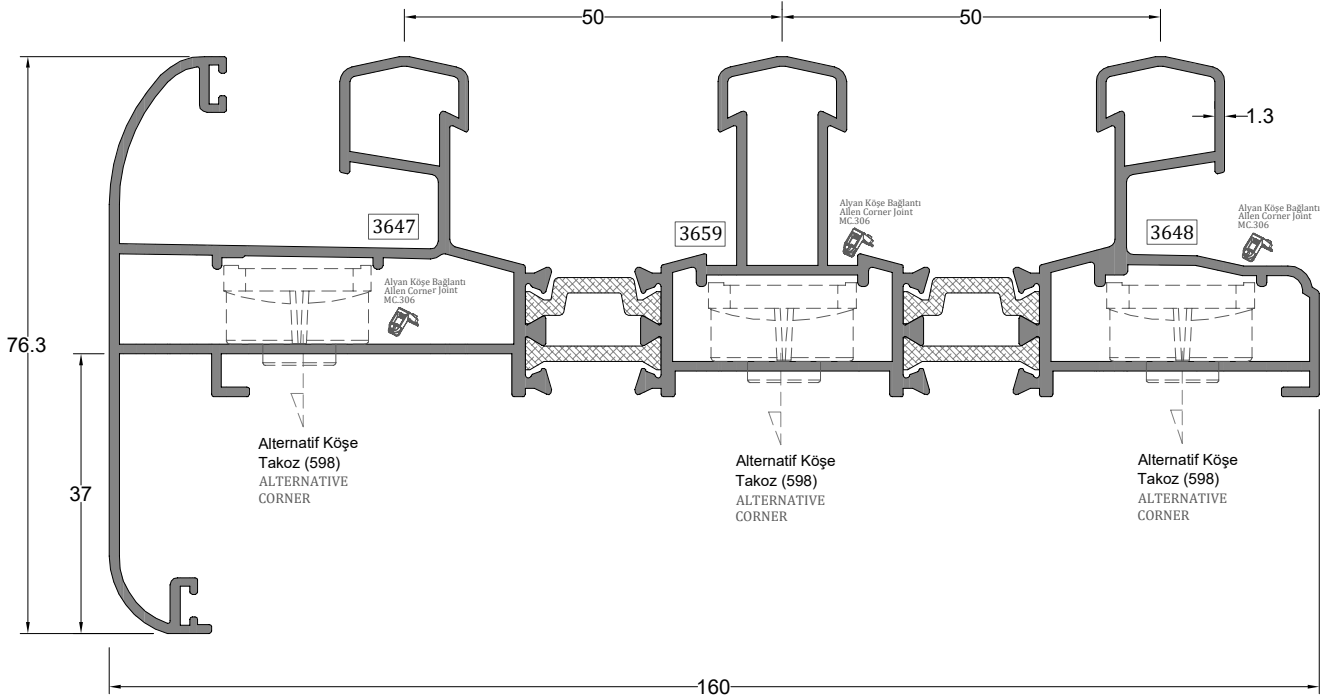

Üç Raylı Kasa Profili	Profil Kodu	(kg/mt)	Jx cm <sup>4</sup>	Jy cm <sup>4</sup>
TRIPLE RAIL FRAME PROFILE	Profile Code	Weight		
	3647-3659-3648	2,950	245,29	25,67

\*\* Her profil için minimum sipariş 300 kg'dır.  
\*\* Minimum order quantity is 300 kg per profile.

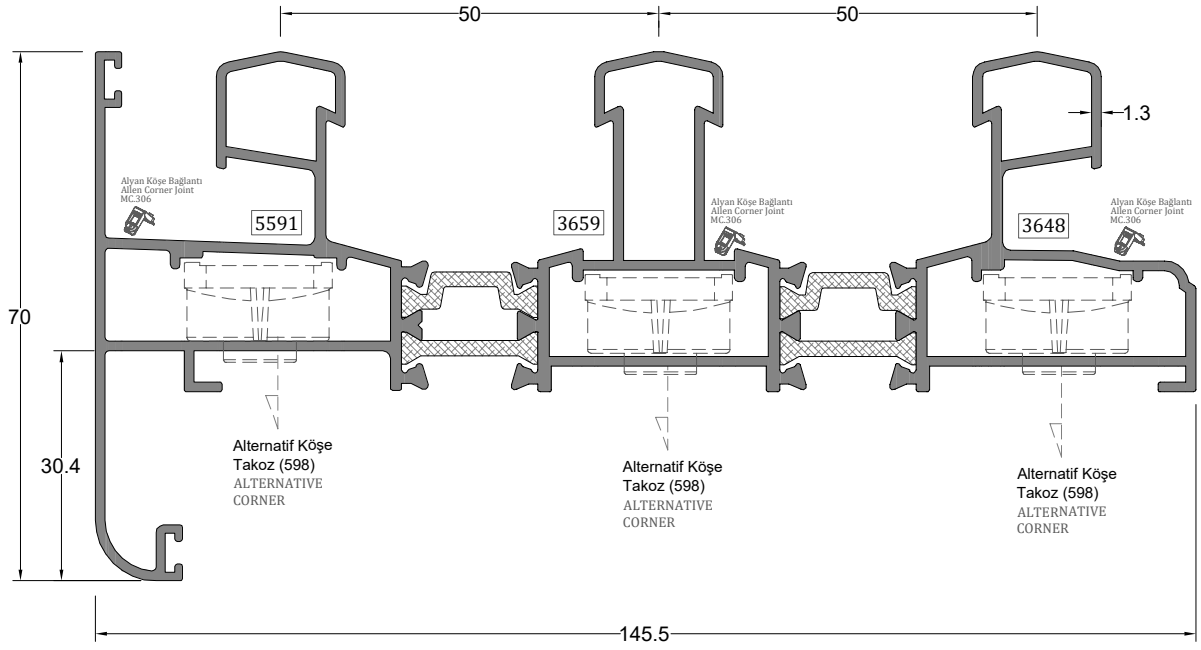

Üç Raylı Kasa Profili TRIPLE FRAME PROFILE	Profil Kodu Profile Code	(kg/mt) Weight	Jx cm <sup>4</sup>	Jy cm <sup>4</sup>
	5591-3659-3648	2,790	192,60	21,74

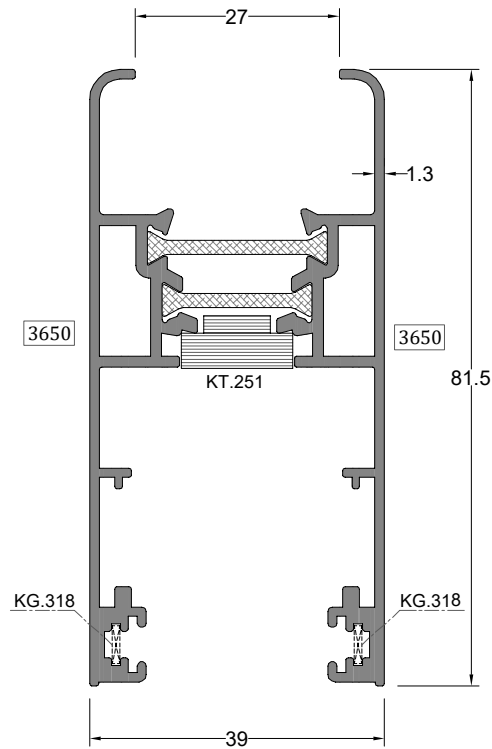

Kanat Profili SASH PROFILE	Profil Kodu Profile Code	(kg/mt) Weight	Jx cm <sup>4</sup>	Jy cm <sup>4</sup>
	3650-3650	1,412	25,18	12,03

\*\* Her profil için minimum sipariş 300 kg'dır.  
\*\* Minimum order quantity is 300 kg per profile.

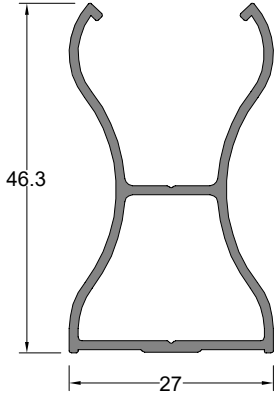

Takviye Profili REINFORCE PROFILE	Profil Kodu Profile Code	(kg/mt) Weight
	3594	0,456

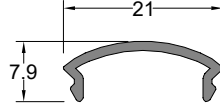

Takviye Kapak Profili REINFORCE COVER PROFILE	Profil Kodu Profile Code	(kg/mt) Weight
	3595	0,101

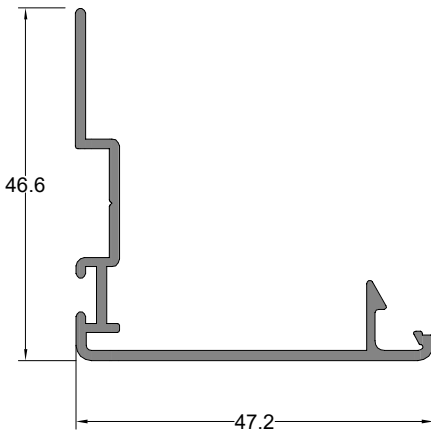
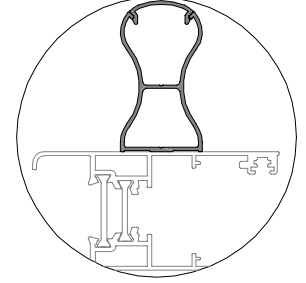

Kenet Profili INTERLOCK PROFILE	Profil Kodu Profile Code	(kg/mt) Weight
	3651	0,415

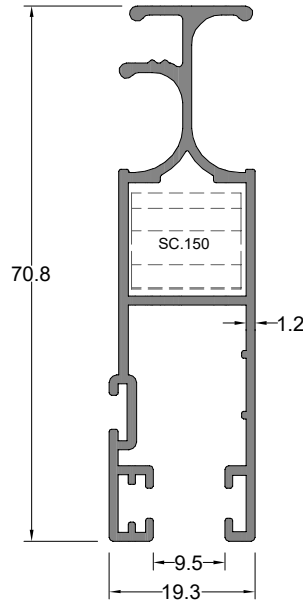

Sineklik Kanat Profili SCREENING SASH PROFILE	Profil Kodu Profile Code	(kg/mt) Weight
	12339	0,703

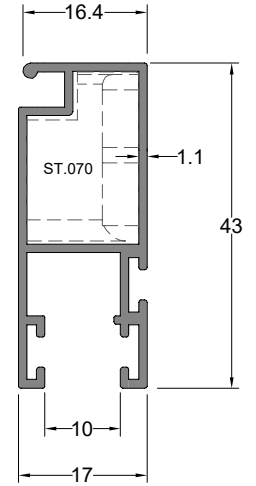

Sineklik Ray Profili SCREENING RAIL PROFILE	Profil Kodu Profile Code	(kg/mt) Weight
	1243	0,434

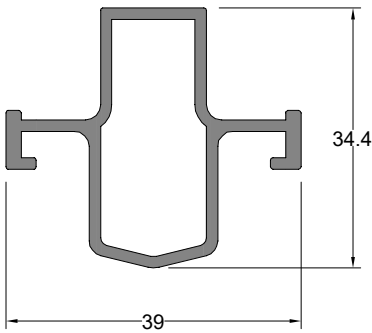

Adaptör Profili ADAPTÖR PROFILE	Profil Kodu Profile Code	(kg/mt) Weight
	3649	0,548

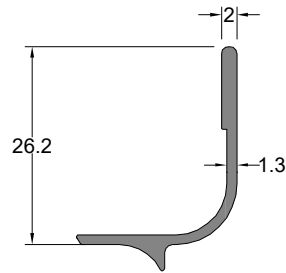

Sineklik Ray Profili SCREENING RAIL PROFILE	Profil Kodu Profile Code	(kg/mt) Weight
	2707	0,190

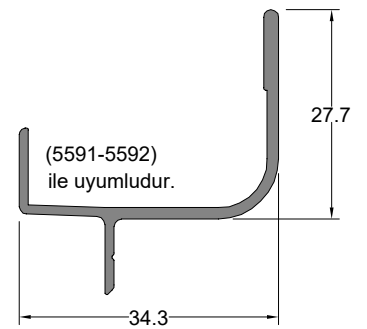

Damlalık Profili DROPPER PROFILE	Profil Kodu Profile Code	(kg/mt) Weight
	5598	0,302

\*\* Her profil için minimum sipariş 300 kg'dır.  
\*\* Minimum order quantity is 300 kg per profile.

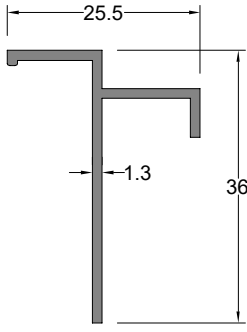

T Bağlantı Profili	Profil Kodu	(kg/mt)
T CONNECTION PROFILE	Profile Code	Weight
	1121	0,233

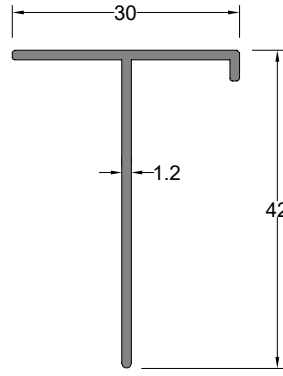

T Bağlantı Profili	Profil Kodu	(kg/mt)
T CONNECTION PROFILE	Profile Code	Weight
	1035	0,240

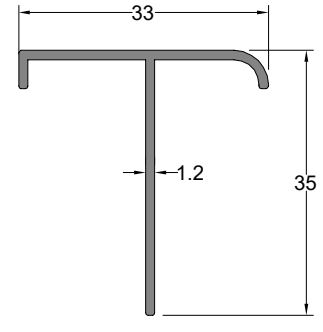

T Bağlantı Profili	Profil Kodu	(kg/mt)
T CONNECTION PROFILE	Profile Code	Weight
	1139	0,236

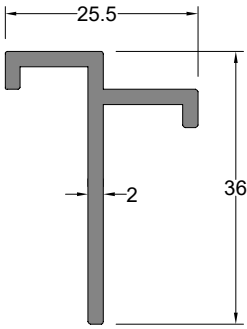

T Bağlantı Profili	Profil Kodu	(kg/mt)
T CONNECTION PROFILE	Profile Code	Weight
	1123	0,355

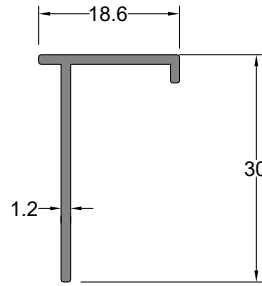

T Bağlantı Profili	Profil Kodu	(kg/mt)
T CONNECTION PROFILE	Profile Code	Weight
	3917	0,162

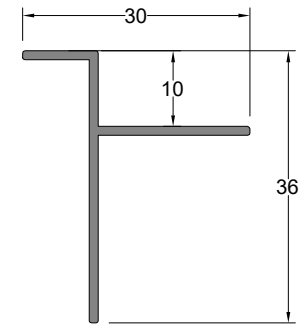

T Bağlantı Profili	Profil Kodu	(kg/mt)
T CONNECTION PROFILE	Profile Code	Weight
	3818	0,210

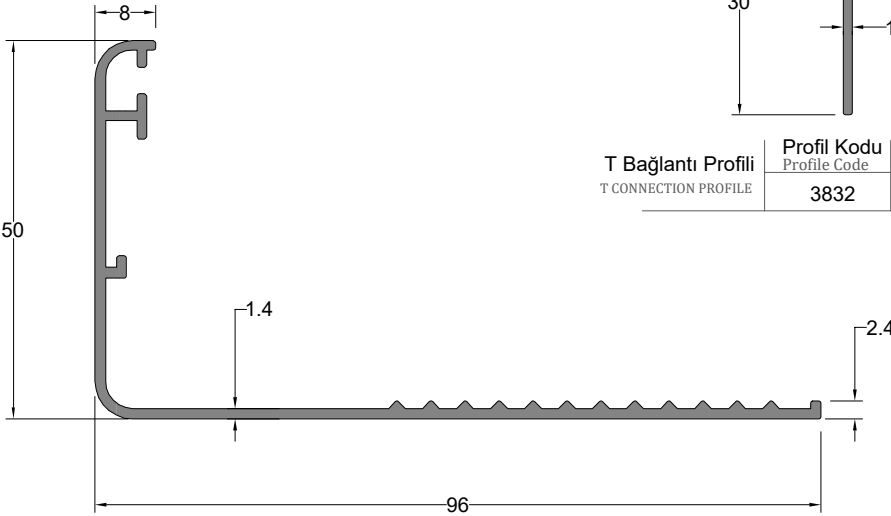

Pervaz Profili	Profil Kodu	(kg/mt)
SILL PROFILE	Profile Code	Weight
	553	0,656

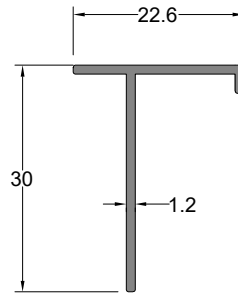

T Bağlantı Profili	Profil Kodu	(kg/mt)
T CONNECTION PROFILE	Profile Code	Weight
	3832	0,175

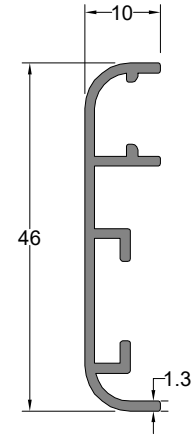

Pervaz Profili	Profil Kodu	(kg/mt)
SILL PROFILE	Profile Code	Weight
	3646	0,302

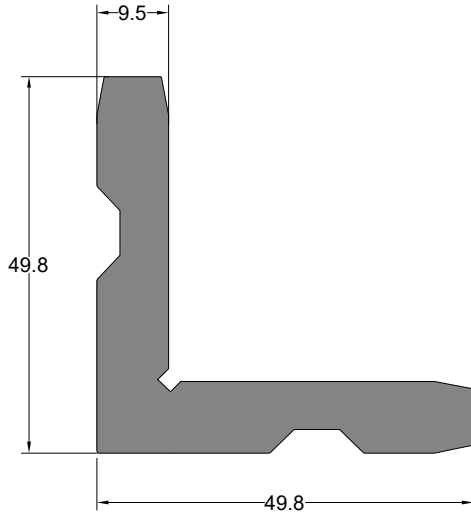

Köşe Takoz Profili CORNER WEDGE PROFILE	Profil Kodu Profile Code	(kg/mt) Weight
	6568	2,128

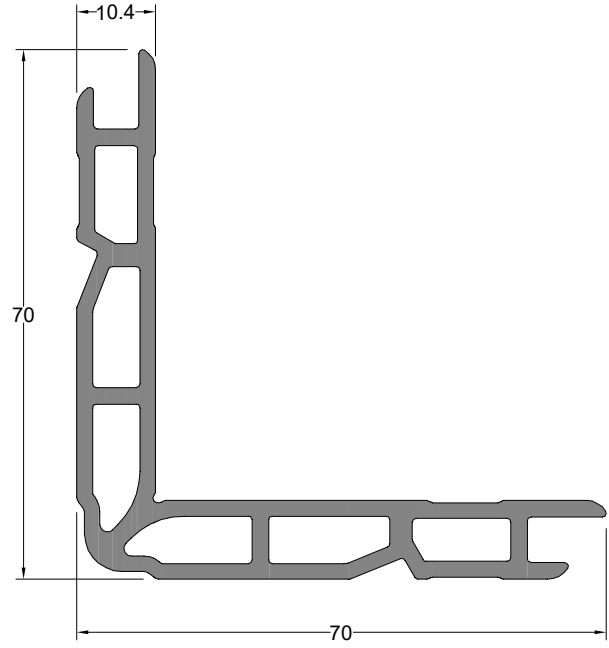

Köşe Takoz Profili CORNER WEDGE PROFILE	Profil Kodu Profile Code	(kg/mt) Weight
	598	1,760

**KÖŞE TAKOZU KESİM ÖLÇÜLERİ**

	Profil Kodu PROFILE CODE	Köşe Takoz CORNER JOINT	Kesim Ölçüsü CUT. DEM.
	3647-3648	598	19,5 mm
	5591-5592	598	22,2 mm
	3648-3648	598	19,5 mm
	3647-3659-3648	6568	19,5 mm
	5591-3659-3648 (3659-3648 not profile için)	598	19,5mm
	5591-3659-3648 (5591 not profile için)	598	20,2 mm
	3650-3650	KT.251 	-

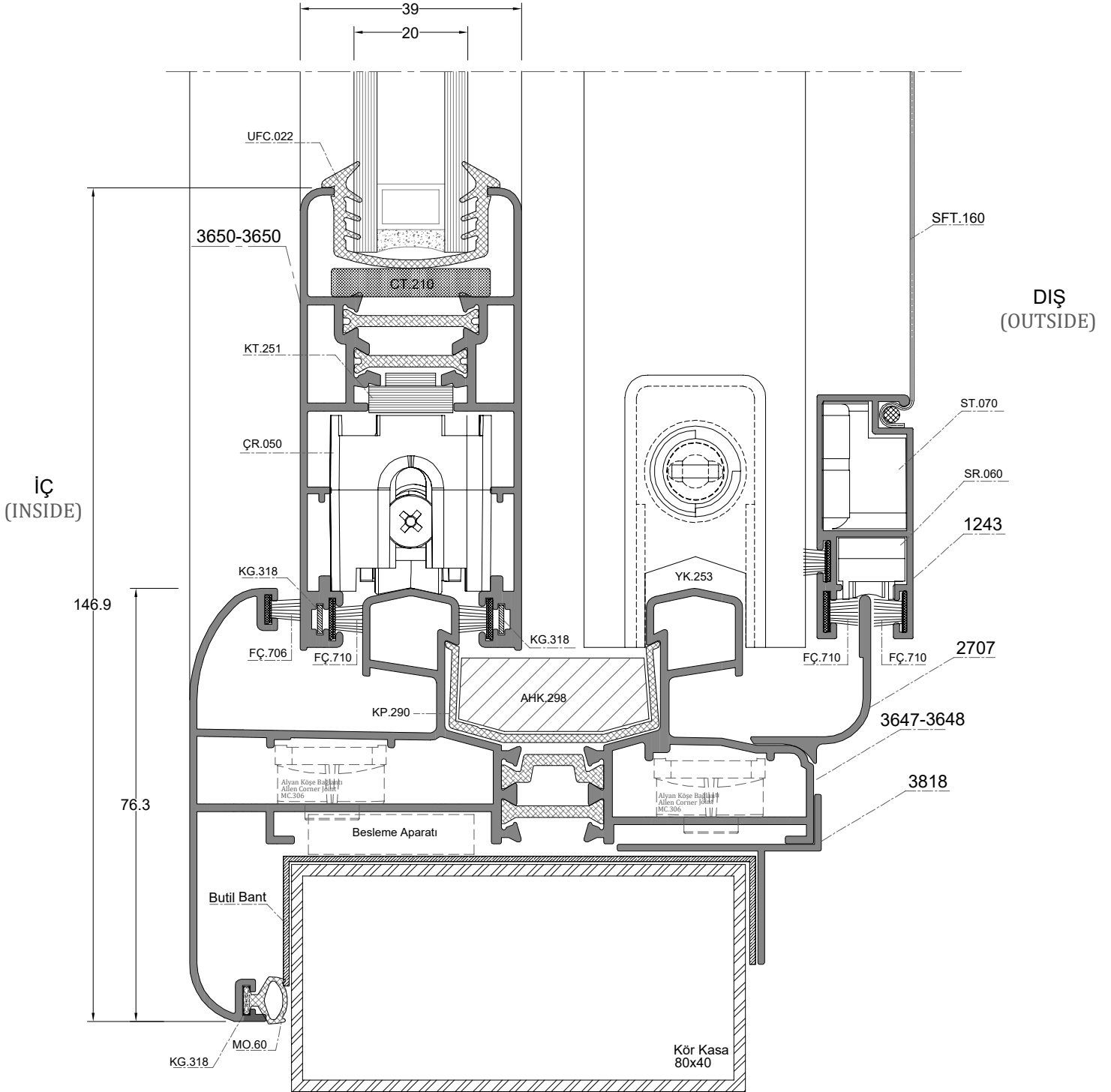
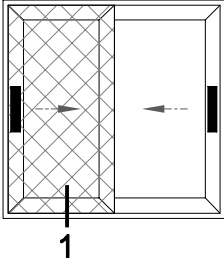

D-1



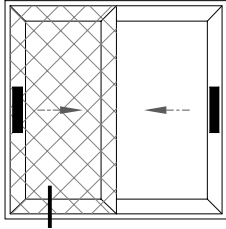

1A

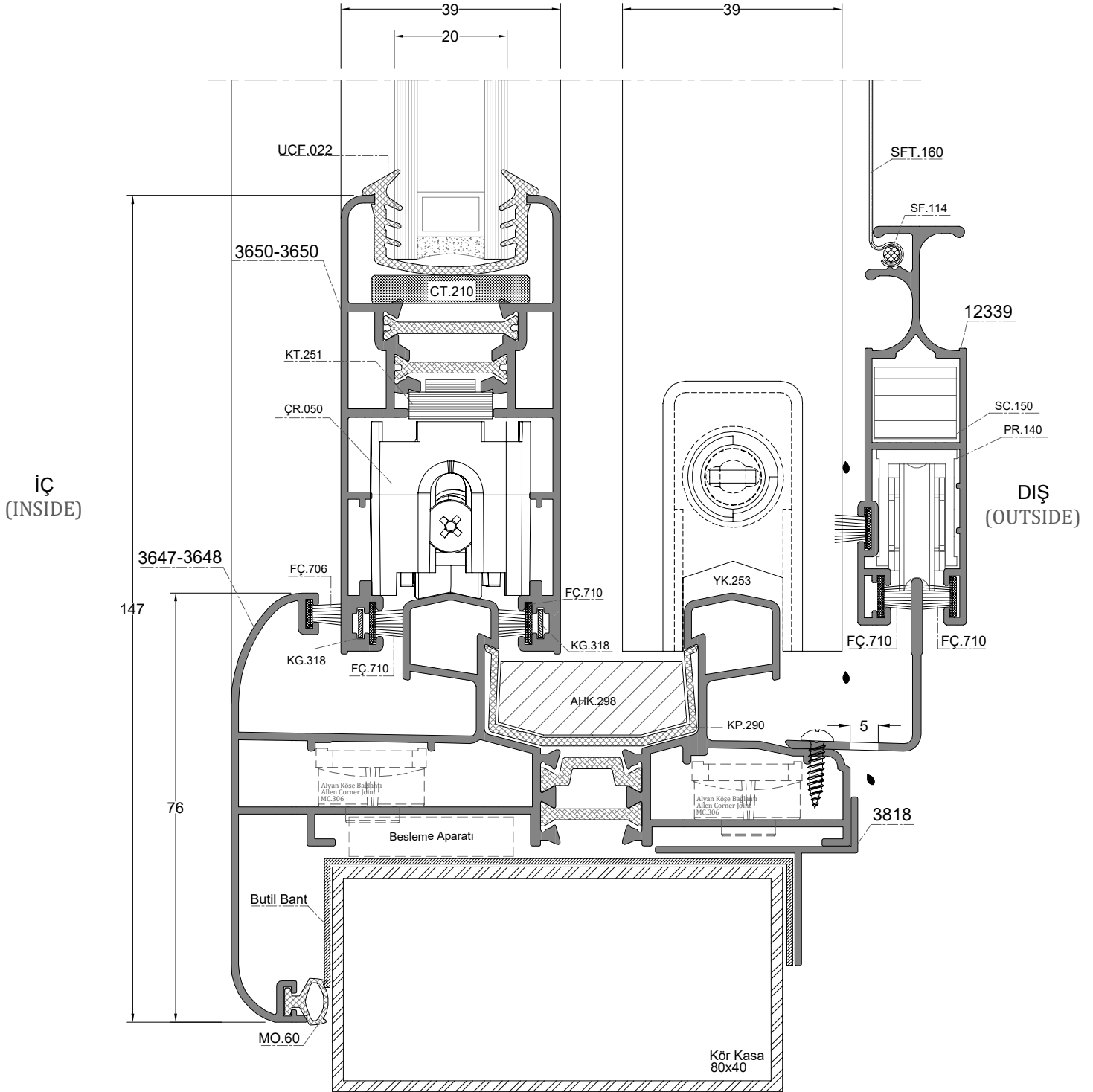

D-1A

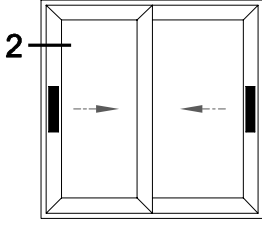

**İÇ**  
(INSIDE)

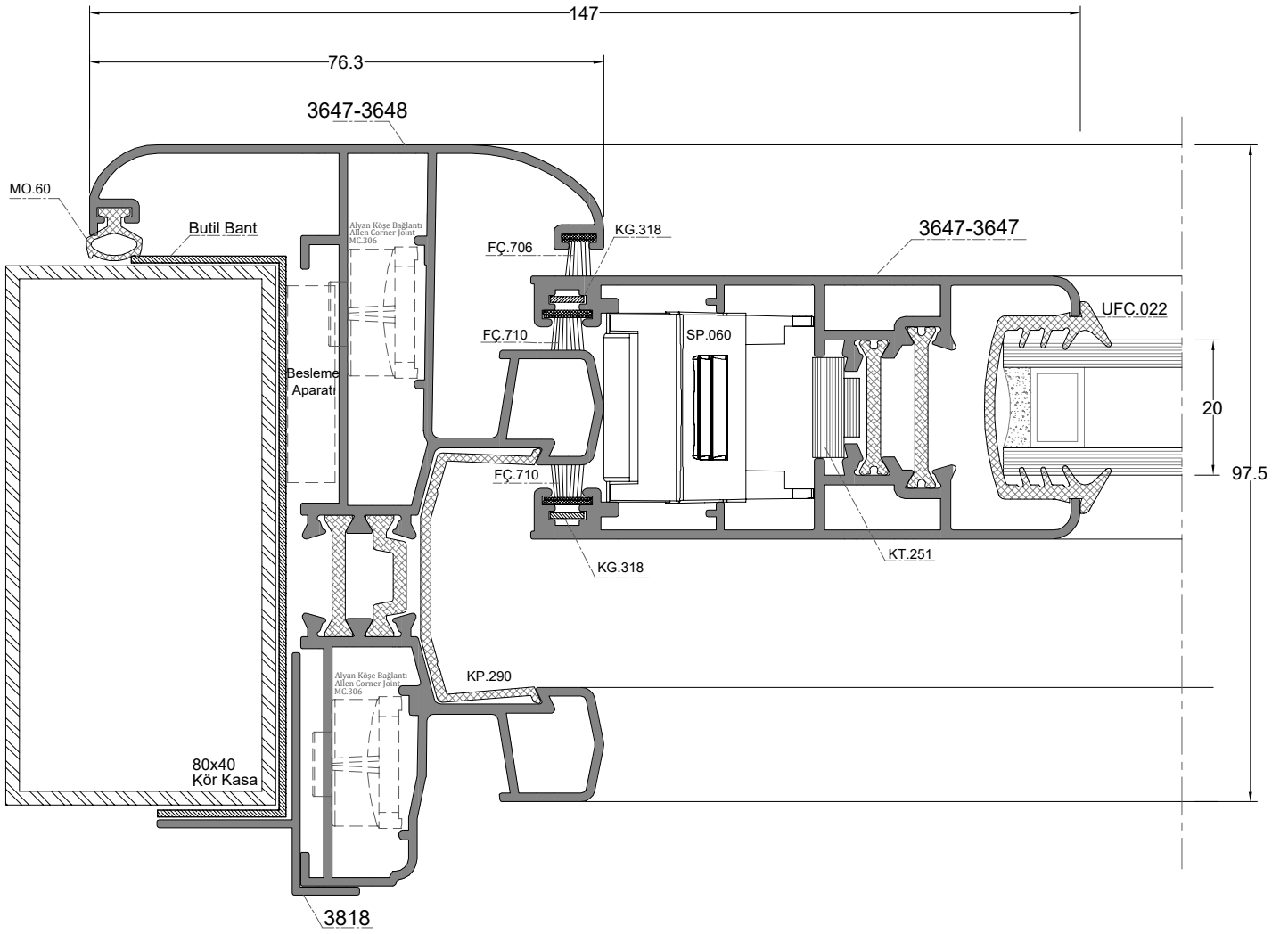

**DIŞ**  
(OUTSIDE)

D-2

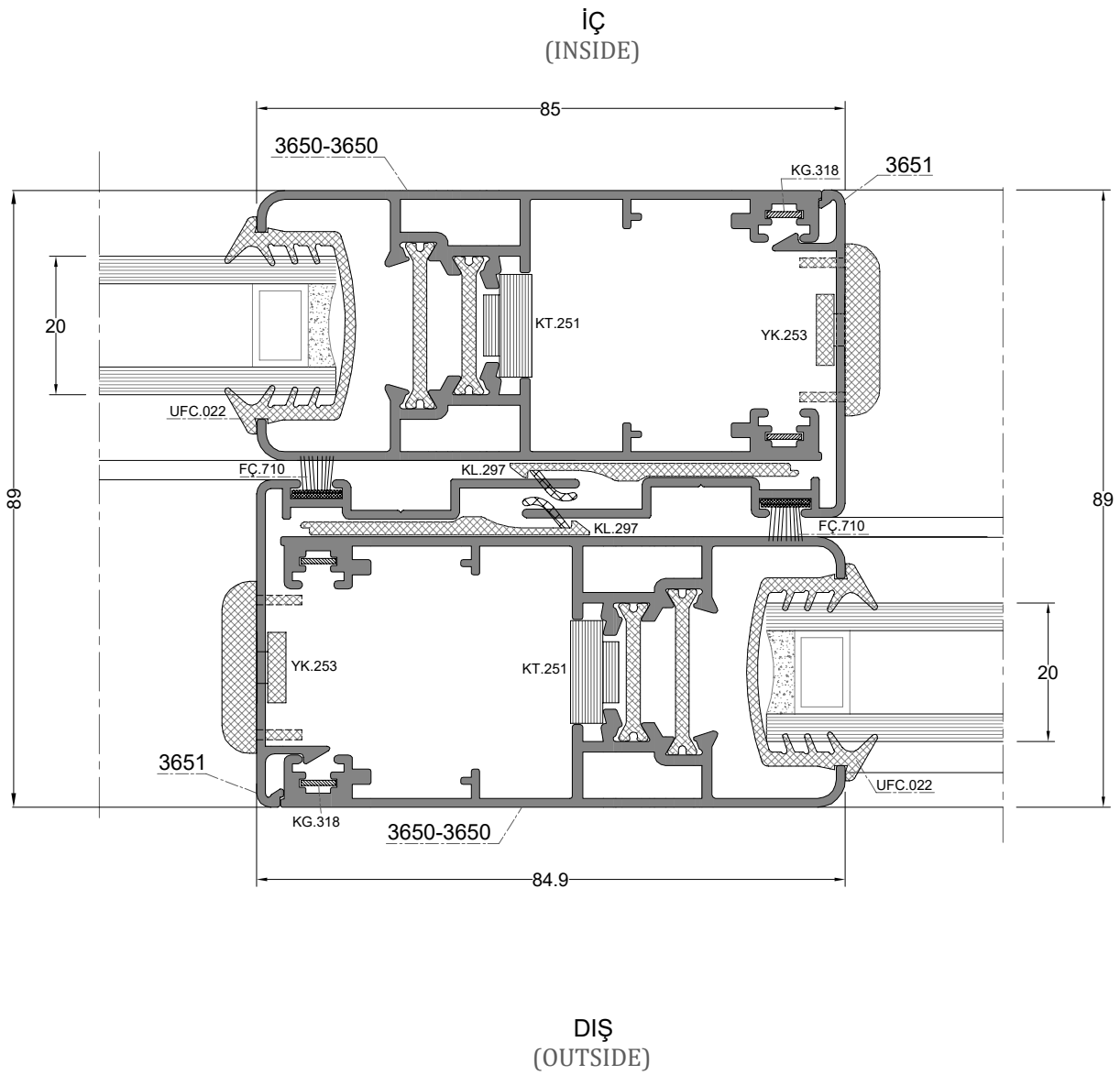
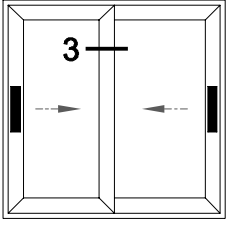

D-3

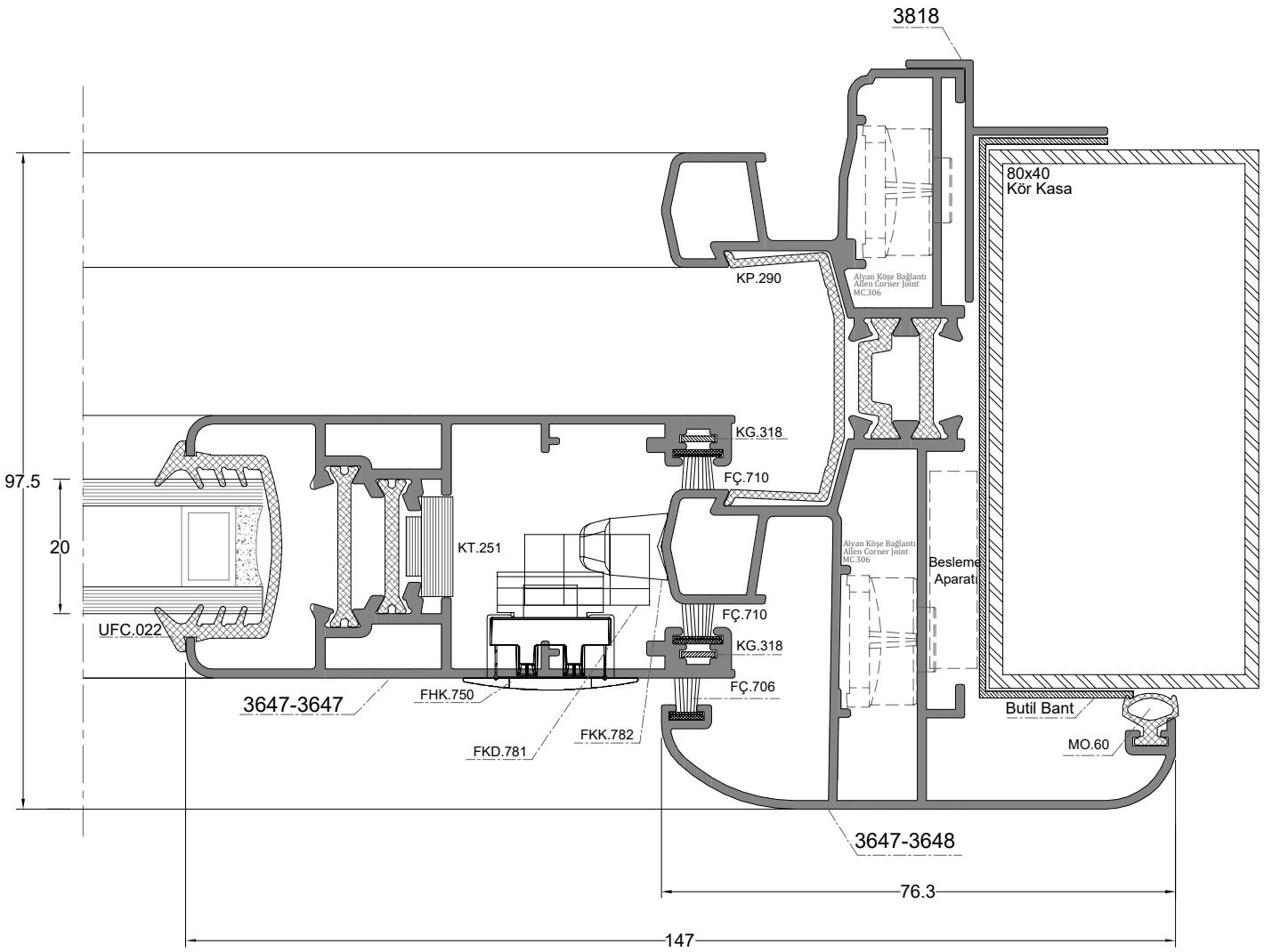
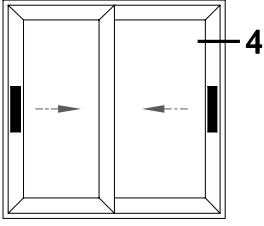

İÇ  
(INSIDE)

D-4

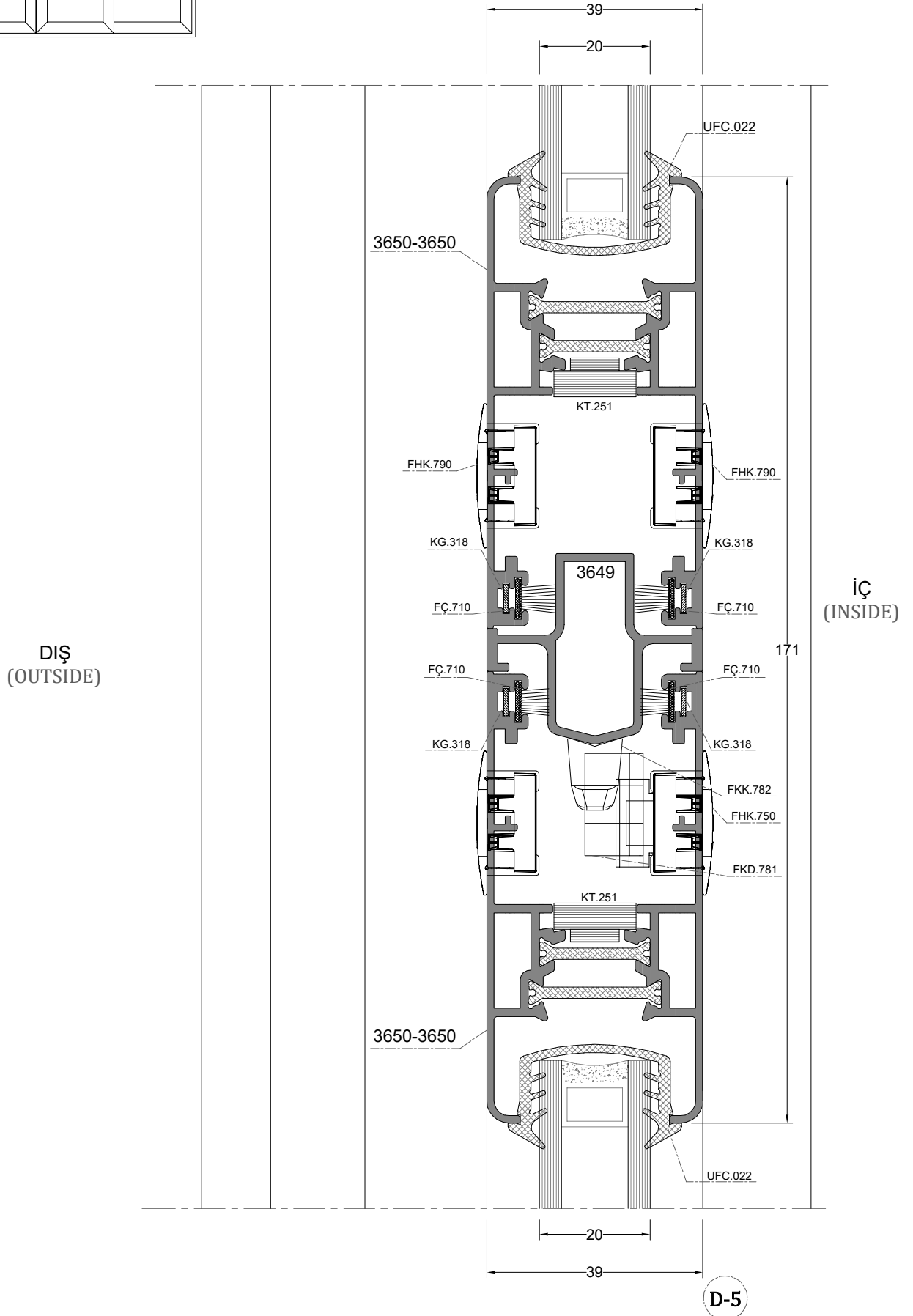
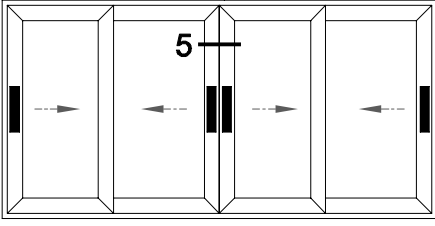

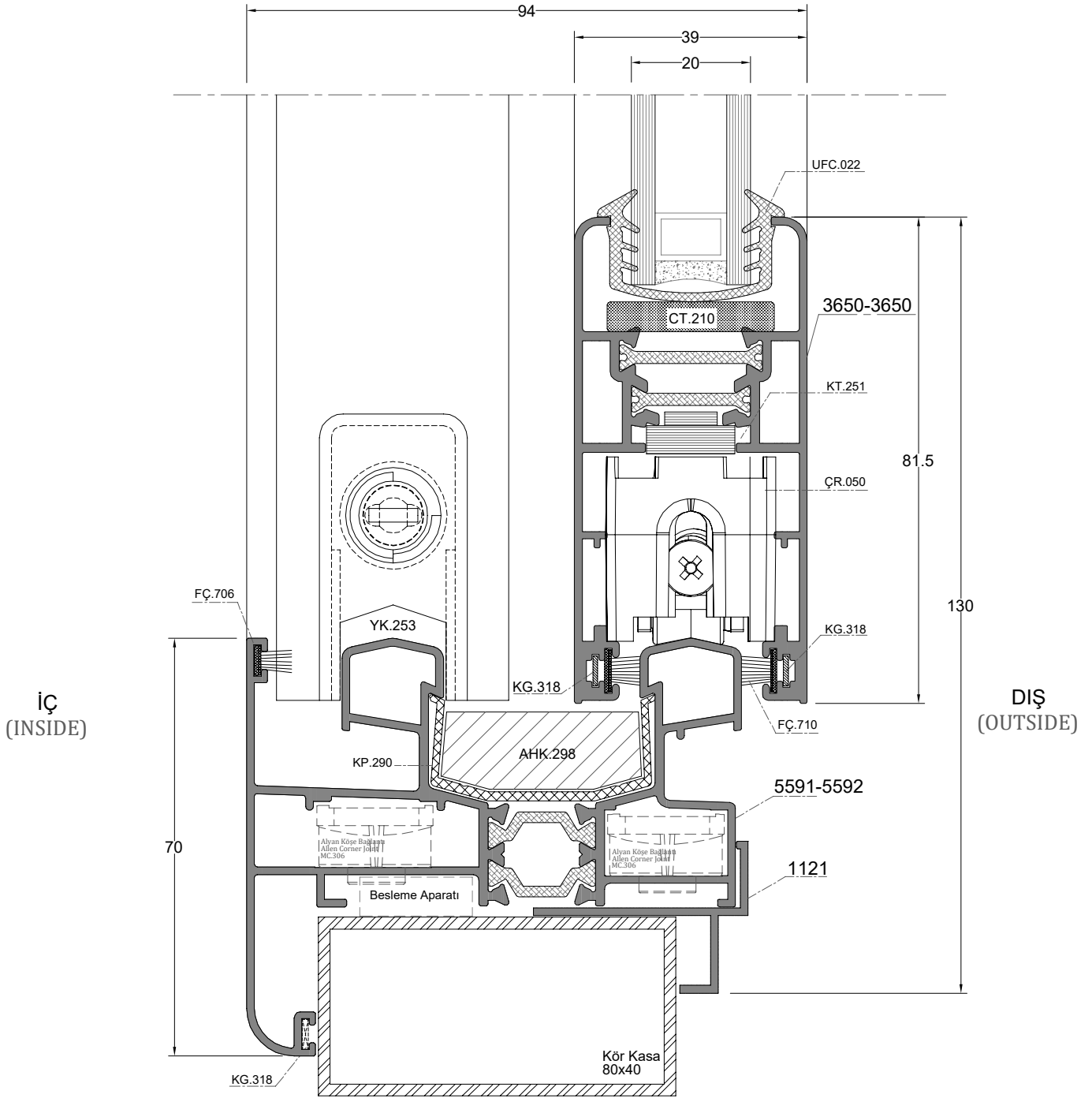
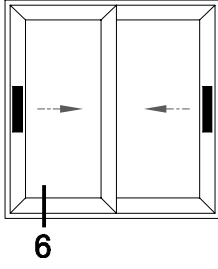

D-6

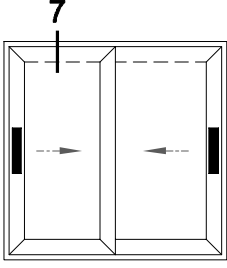

5591-5592 nolu kasa Damlalık ve T profil detayı

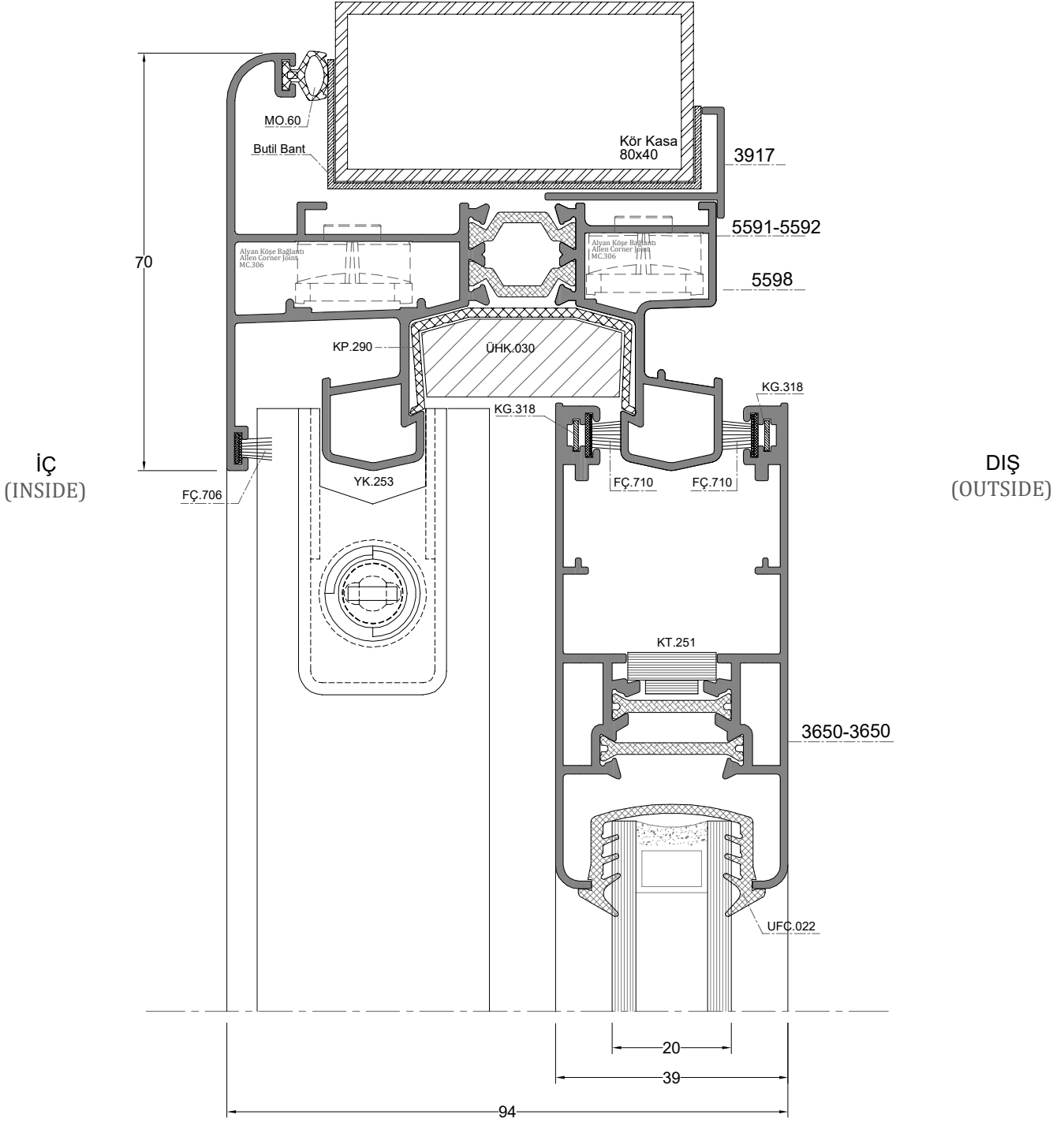

D-7

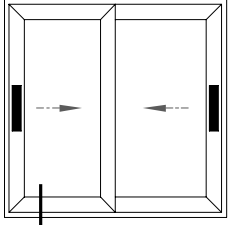

3648-3648 Nolu Kasa Pervaz Detayı

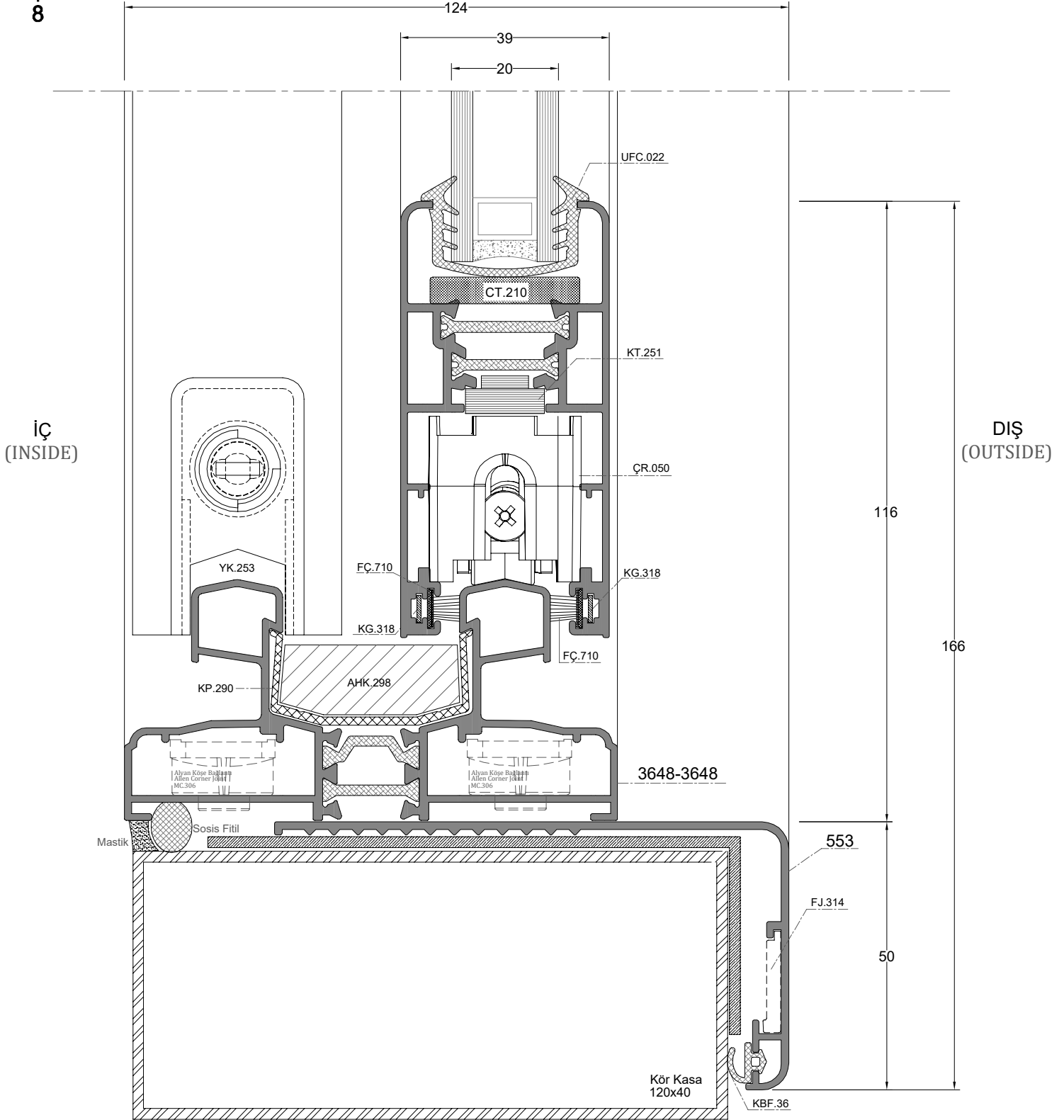

D-8



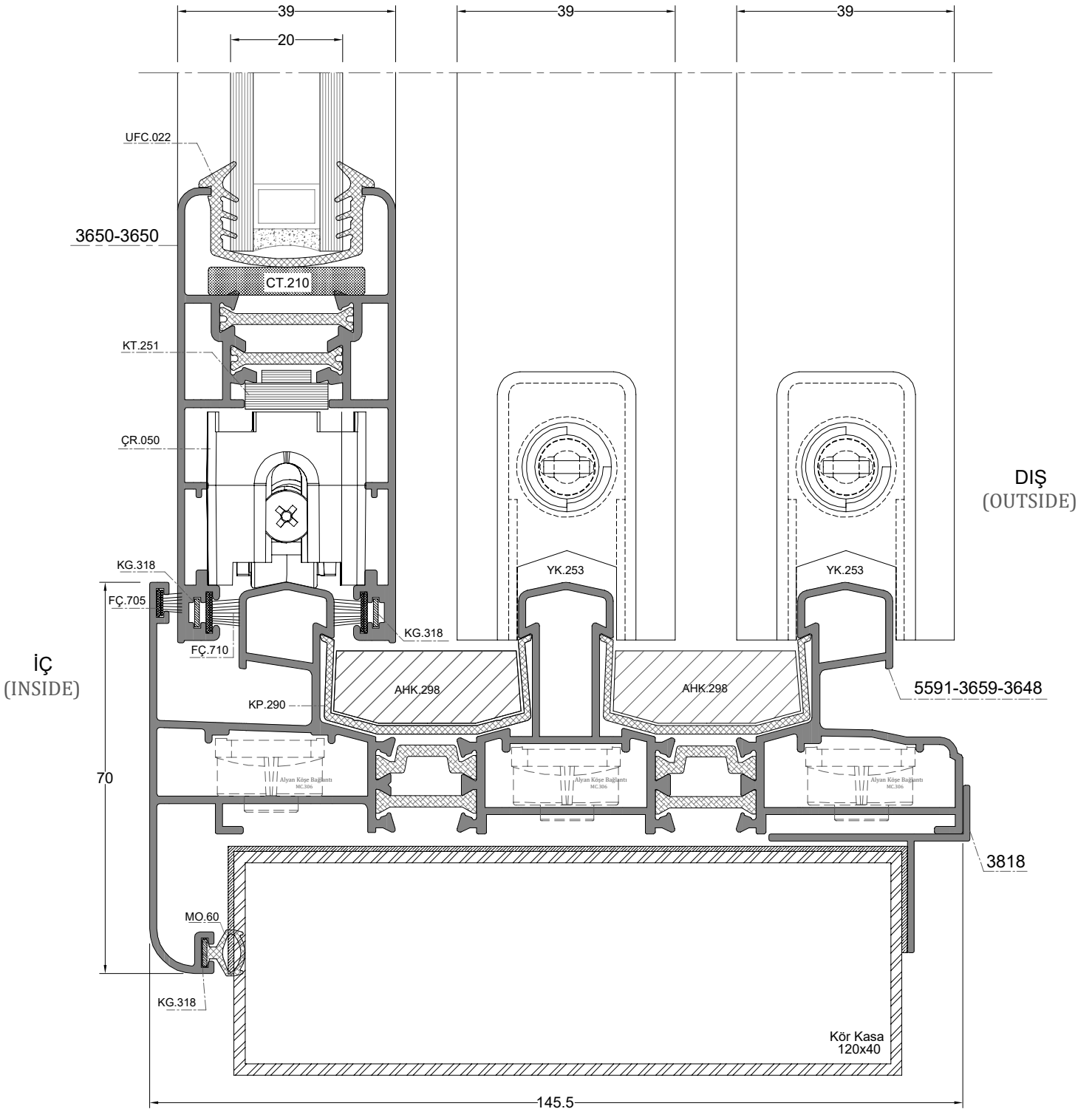
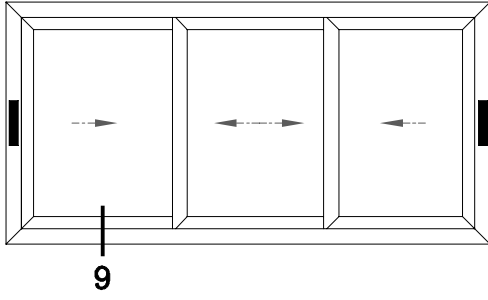

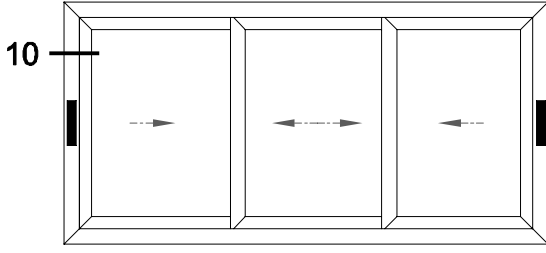

**İÇ**  
(INSIDE)

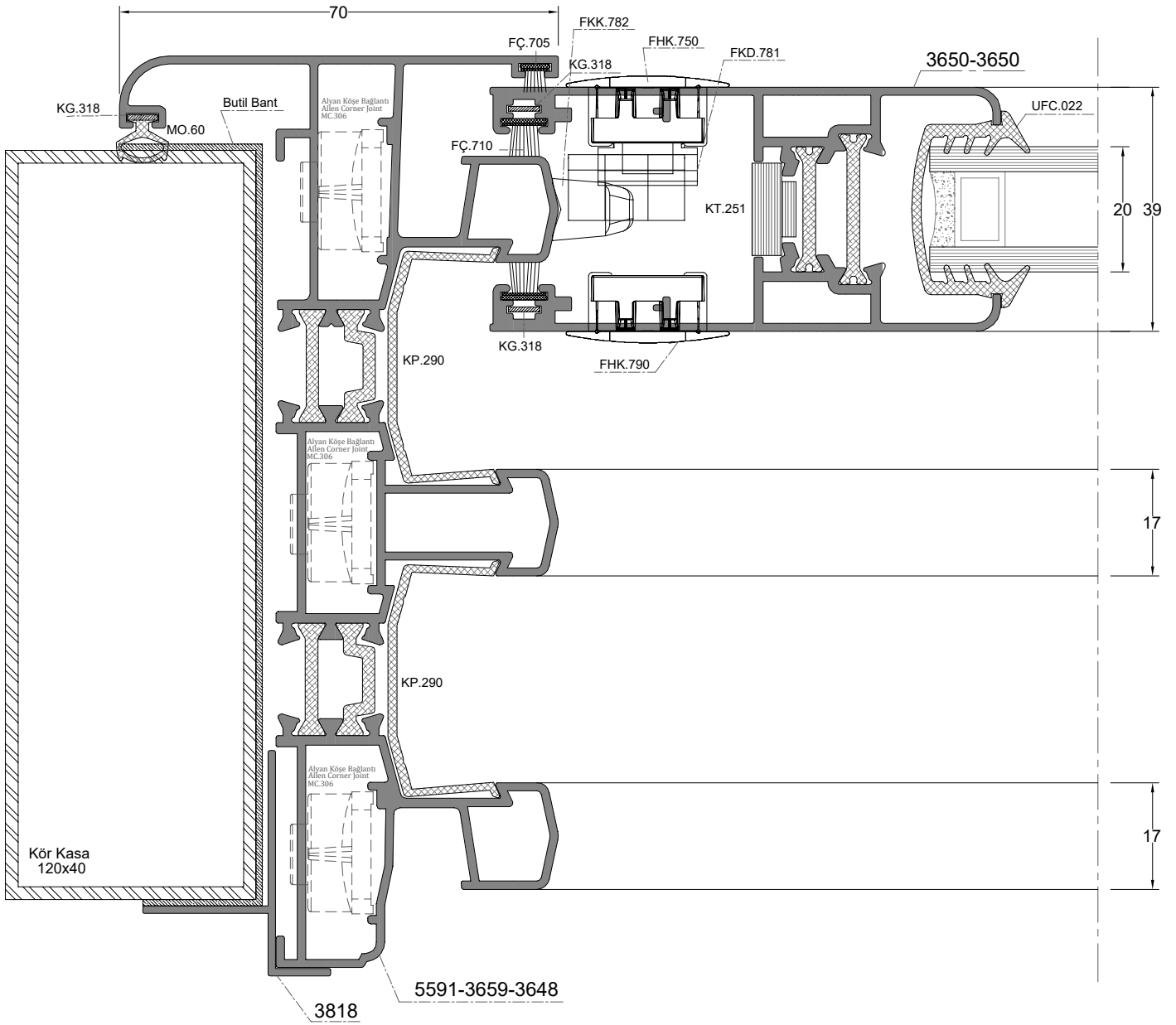

**DIŞ**  
(OUTSIDE)

**D-10**

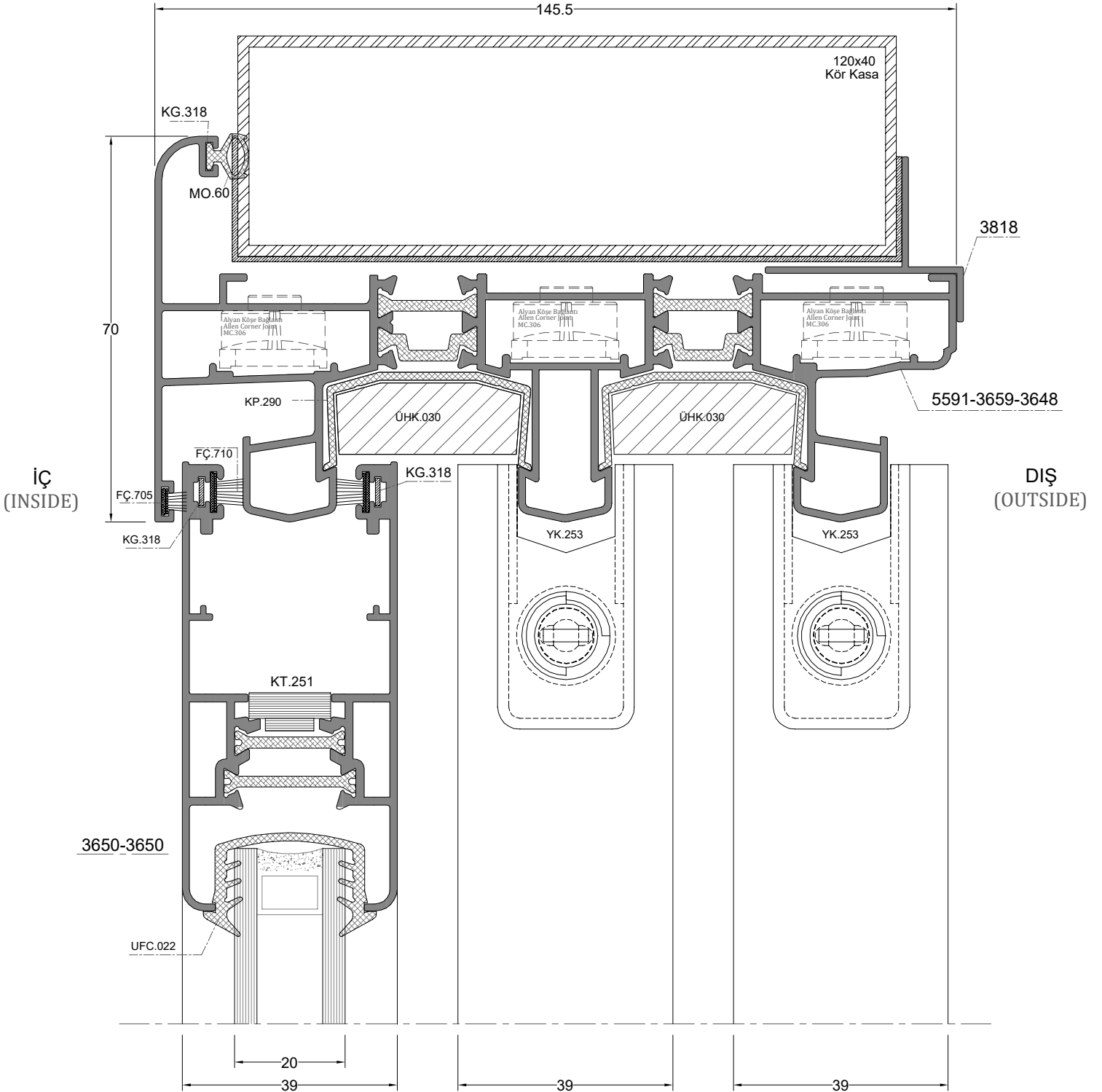
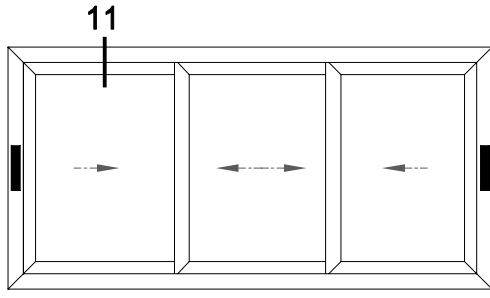

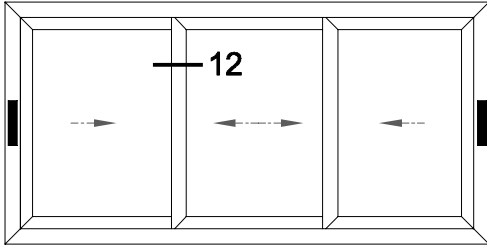

**İÇ**  
(INSIDE)

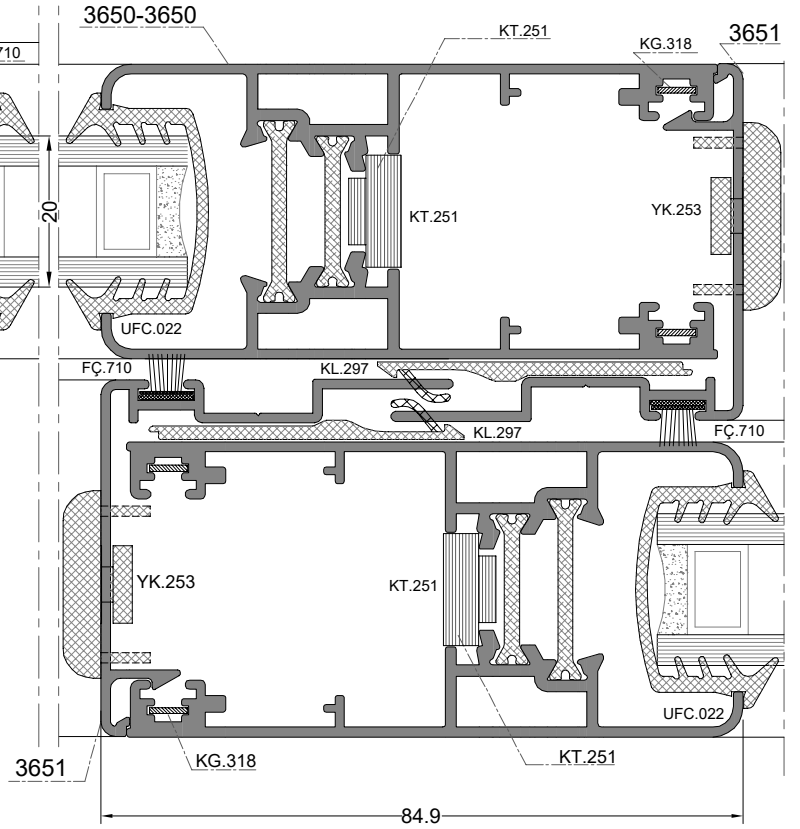
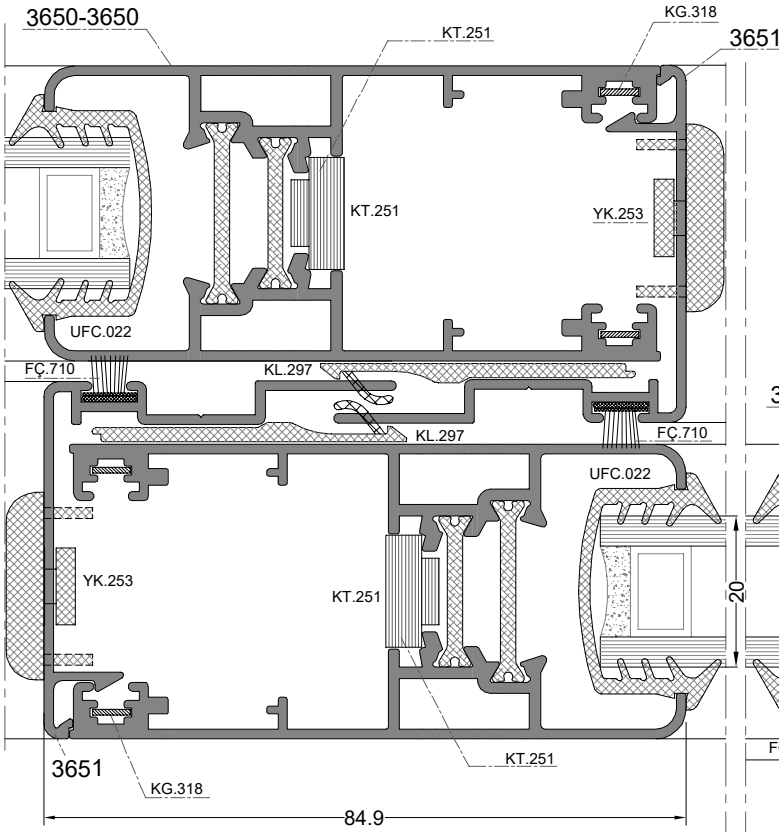

**DIŞ**  
(OUTSIDE)

D-12

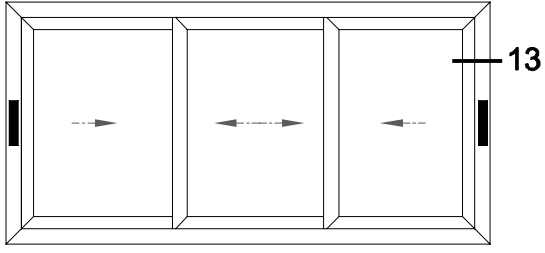

İÇ  
(INSIDE)

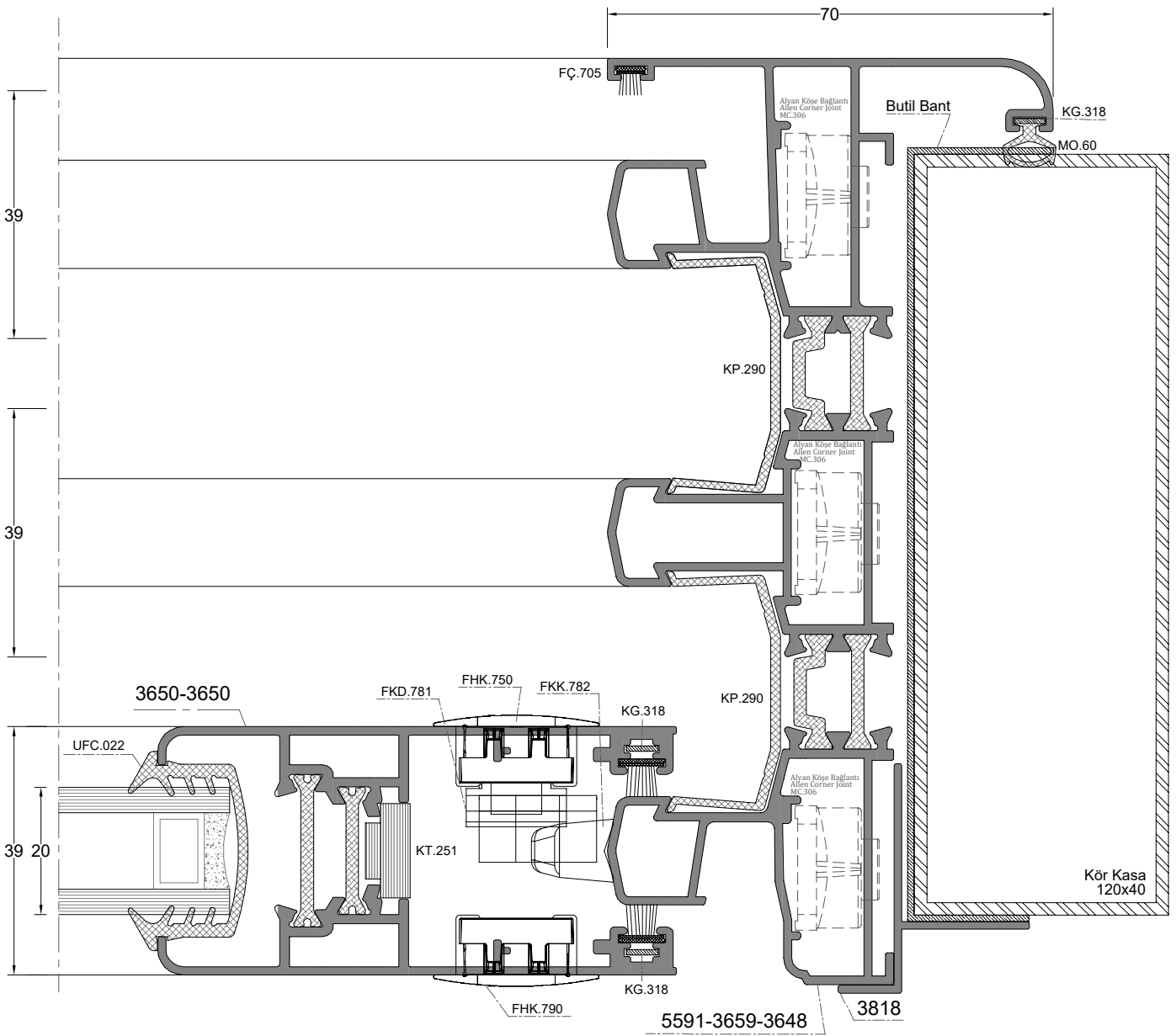

DIŞ  
(OUTSIDE)

D-13

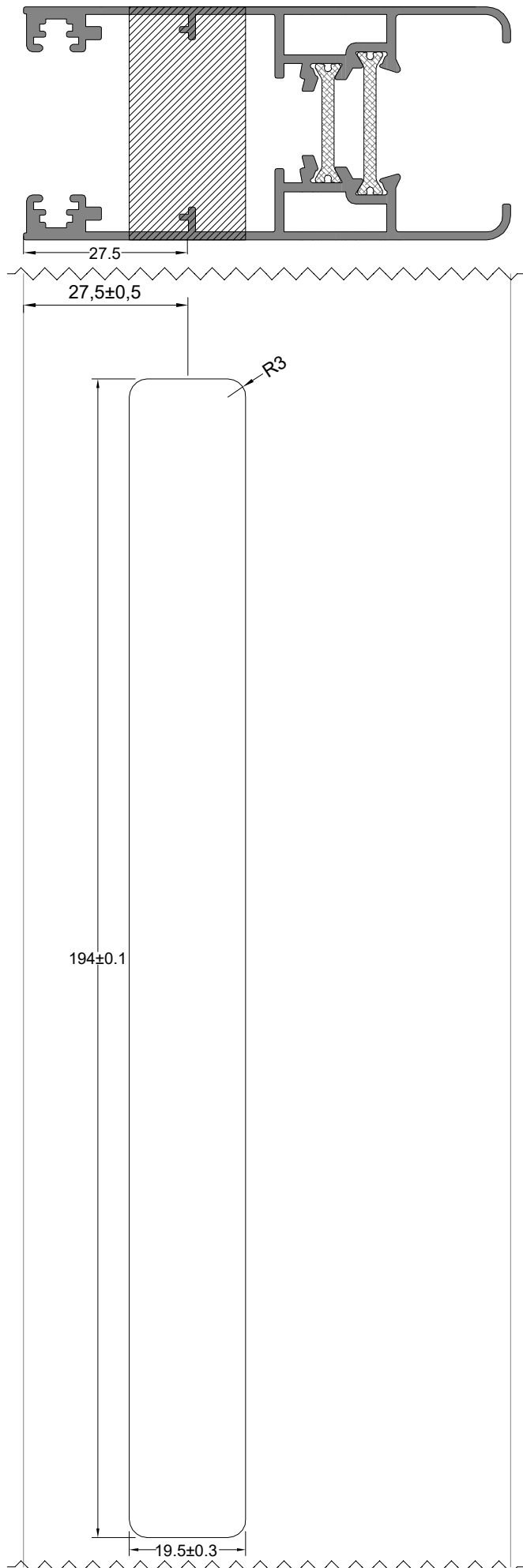

FKH.750

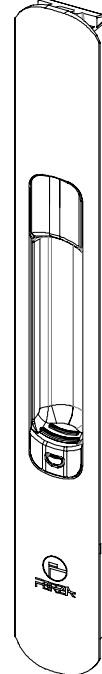

FKD.781

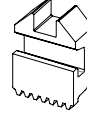

FKK.782

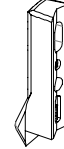

FPK.790

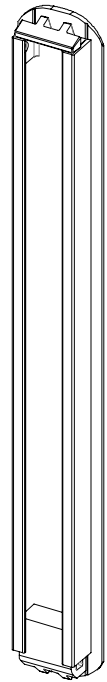

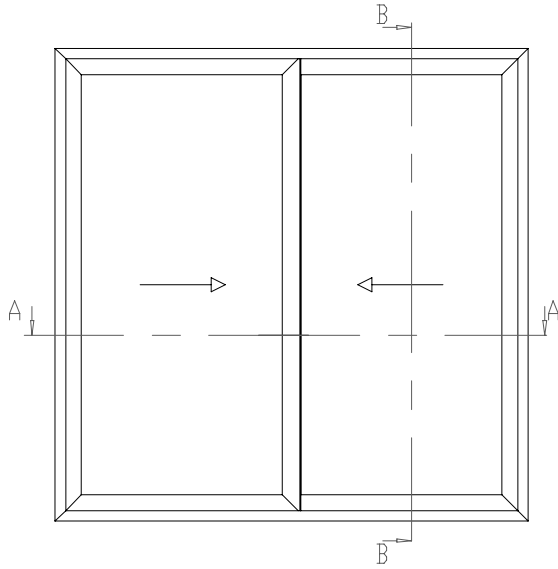

**B-B KESİTİ**

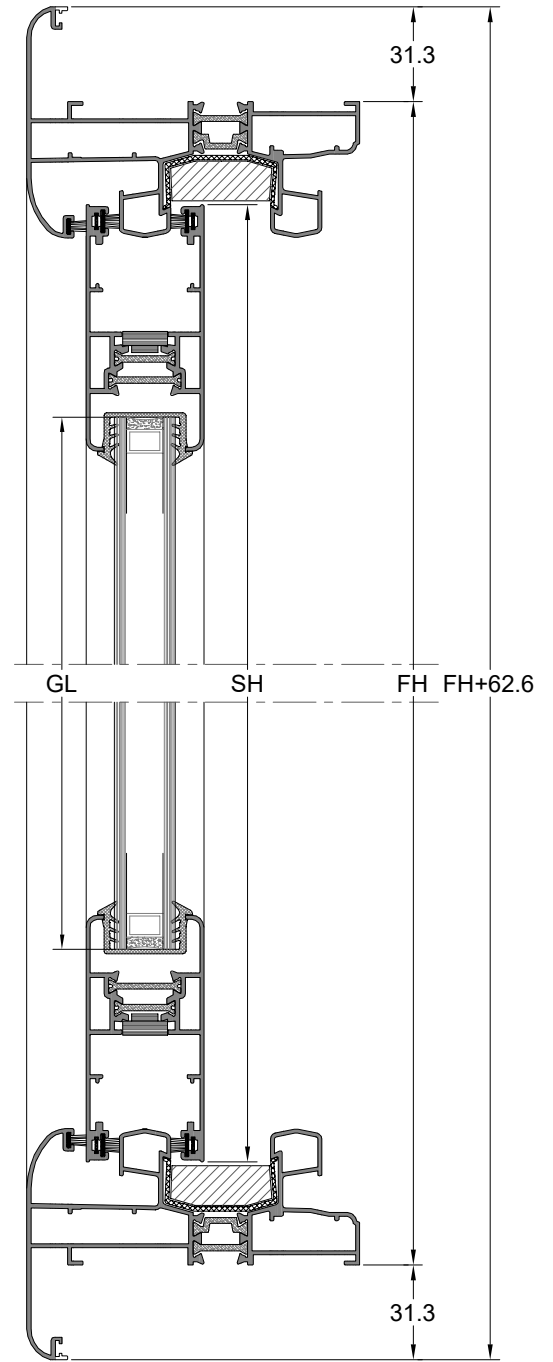

**PROFİLLER / PROFILES**

Kod Code	Çizim Drawing	Kesim Cut	Miktar Quantity	Ölçüler Dimensions
3647-3648 Kasa Frame			2 Pcs / Adet	FL+62.6
			2 Pcs / Adet	FH+62.6
3650-3650 Kanat Sash			4Pcs / Adet	SL = (FL/2)+5
			4Pcs / Adet	SH = FH-68,2

**CAM / GLASS**

Kod Code	Çizim Drawing	Miktar Quantity	Ölçüler Dimensions
CAM GLASS		2 Pcs / Adet	GL = SL-140
			GH = SH-140

CAM ÖLÇÜLERİ EŞİT KABUL EDİLEREK  
FORMULİZE EDİLMİŞTİR.

GLASS DIMENSIONS ARE  
FORMULATED, ACCEPT EQUAL.

**A-A KESİTİ**

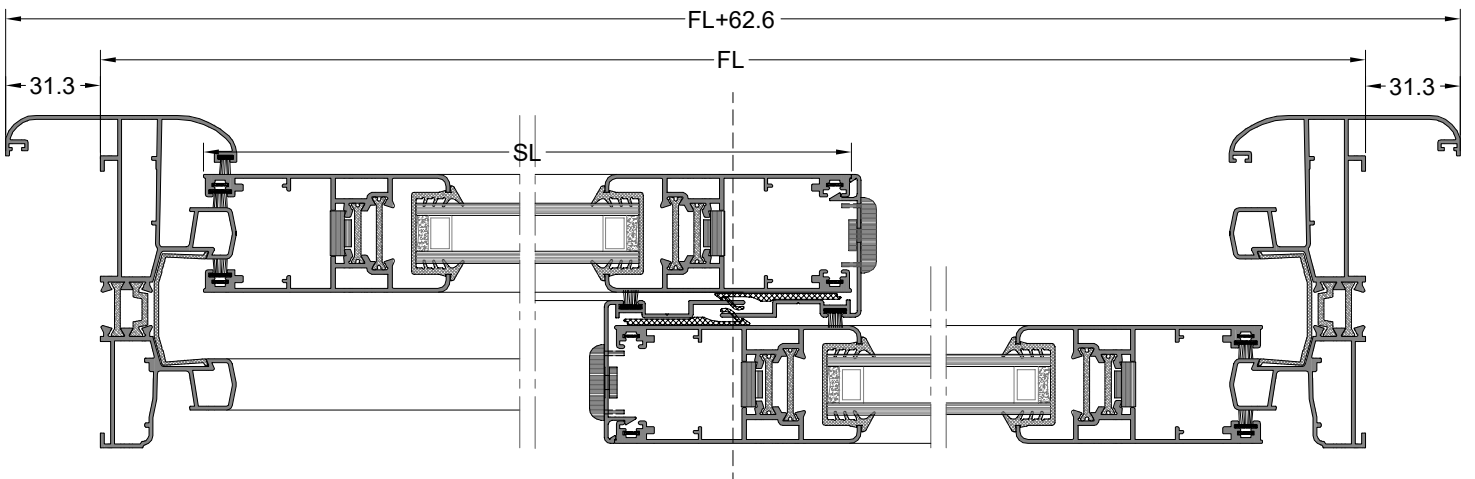

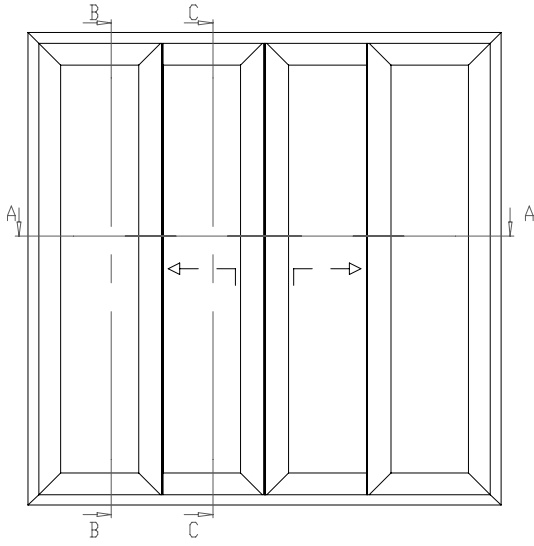

B-B KESİTİ

C-C KESİTİ

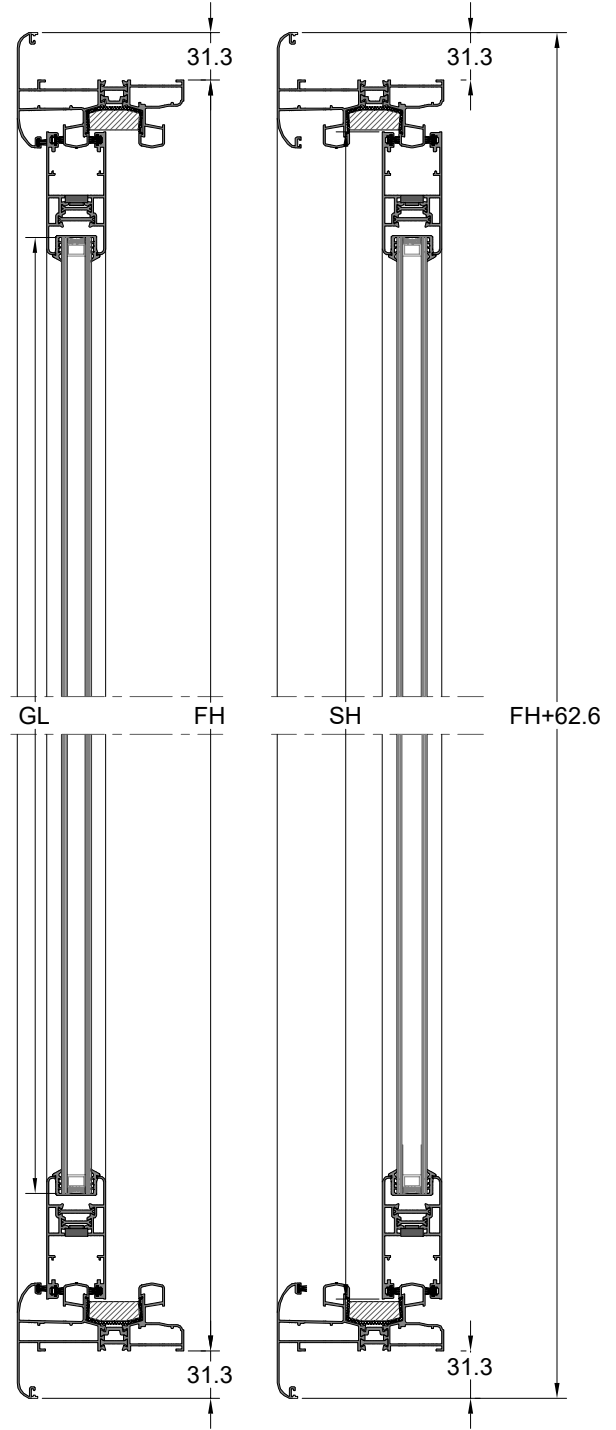

PROFİLLER / PROFILES

Kod Code	Çizim Drawing	Kesim Cut	Miktar Quantity	Ölçüler Dimensions
3647-3648 Kasa Frame			2 Pcs / Adet	FL+62,6
			2 Pcs / Adet	FH+62,6
3650-3650 Kanat Sash			8Pcs / Adet	SL = (FL/4)+20
			8Pcs / Adet	SH = FH-68,2
3649 Adaptör Adapter			1Pcs / Adet	AH = FH-90

CAM / GLASS

Kod Code	Çizim Drawing	Miktar Quantity	Ölçüler Dimensions
CAM GLASS		4 Pcs / Adet	GL = SL-140
			GH = SH-140

CAM ÖLÇÜLERİ EŞİT KABUL EDİLEREK FORMULİZE EDİLMİŞTİR.

GLASS DIMENSIONS ARE FORMULATED, ACCEPT EQUAL.

A-A KESİTİ

